



**Sewanee Village +**  
Pattern Book





# Table of Contents

**Introduction . . . . . 1**  
**Sewanee Village Regulating Plan . . . . . 2**  
**Sewanee Village Character . . . . . 3**  
**Preferred Architects . . . . . 4**  
**The Sewanee Village Planner . . . . . 5**  
**Village Character Districts . . . . . 6**  
**How To Use This Pattern Book . . . . . 7**  
**Illustrated Concepts & Terms . . . . . 10**

## **Residential Standards**

### **Residential Lot Patterns**

**Village Edge . . . . . 12**  
**Village Neighborhood . . . . . 14**  
**Cottage Court . . . . . 16**  
**Carriage House/Garage Placement . . . . . 18**

### **General Architectural Standards**

**Private Frontage Types . . . . . 20**  
**Building Types . . . . . 22**  
**Building Composition & Massing . . . . . 24**  
**Building Configuration . . . . . 25**  
**Building Materials & Details . . . . . 26**  
**Windows & Openings . . . . . 30**  
**Doors . . . . . 37**  
**Roofs . . . . . 38**

**Porches, Stoops, Decks & Balconies . . . . . 46**  
**Chimneys . . . . . 47**  
**Carriage Houses, Garages & Outbuildings . . . . . 48**

## **Residential Landscape Standards**

**Residential Driveways . . . . . 50**  
**Fences, Walls & Hedges . . . . . 51**

## **Architectural Style Standards**

**Introduction . . . . . 55**  
**Local Precedent - Residential . . . . . 56**  
**Regional Precedent - Residential . . . . . 57**  
**National Precedent - Residential . . . . . 58**  
**Village Architectural Styles - Summary . . . . . 59**  
**Folk . . . . . 61**  
**Folk Victorian . . . . . 66**  
**Craftsman . . . . . 72**  
**Colonial Revival . . . . . 77**  
**Ranch . . . . . 82**  
**Sewanee Eclectic . . . . . 83**



**Mixed-Use & Commercial Standards**

**Introduction . . . . . 85**

**Mixed-Use & Commercial Lot Patterns**

Village Center . . . . . 86  
 Village Edge . . . . . 88

**Mixed-Use & Commercial Architectural Standards**

Private Frontage Types . . . . . 90  
 Building Types . . . . . 92  
 Shopfront Frontage . . . . . 93  
 Local Precedent - Mixed-Use & Commercial . . . . . 96  
 Regional Precedent - Mixed-Use & Commercial . . . . . 97  
 National Precedent - Mixed-Use & Commercial. . . . . 98

**Sign Standards**

**Introduction . . . . . 101**  
**Summary . . . . . 102**

**Signage Standards**

Address Sign . . . . . 105  
 Awning Sign . . . . . 106  
 Band Sign . . . . . 107  
 Blade Sign . . . . . 108  
 Marquee Sign . . . . . 109  
 Outdoor Display Case . . . . . 110  
 Plaque Sign . . . . . 111  
 Porch Sign. . . . . 112  
 Sidewalk Sign . . . . . 113  
 Wall and Building Sign . . . . . 114  
 Window Sign . . . . . 115  
 Yard Sign . . . . . 116

**Resources . . . . . 117**



**Disclaimer:**

This Pattern Book and the Village Implementation Plan on the following page may be updated from time to time at the discretion of the Village Planner and the University of the South Lease Committee. It is the responsibility of the Leaseholder or Developer to be sure he/she has the most current version of the Pattern Book and the Village Implementation Plan, which will be posted at [Leases.sewanee.edu](https://Leases.sewanee.edu).

This document is intended to be used in its original, color version. If you have printed or received a black and white version, please refer to the color version posted on the Sewanee Village Website for optimized graphics.



## Introduction

In 2015, the Village Implementation Plan was created to enhance the Sewanee Village and make it a more attractive, cohesive, and walkable center for those who visit, live, work, and study in Sewanee. The Plan includes recommendations for mixed-use and residential infill to eliminate gaps in the streetscape and provide additional housing options; improvements to the University Avenue/Hwy 41A intersection; and new public open spaces and pedestrian facilities. The future Village is imagined as a vibrant, economically thriving, unique and special place that incorporates the forms, colors, topography, architecture and landscape of the surrounding Domain.

The Sewanee Village Pattern Book, originally adopted in October 2016, is a tool to guide the construction and renovation of all new and existing structures within the Village boundary, as shown at right. The major goal of the Pattern Book is to create the same level of design and architecture in the Village as on the neighboring University of the South campus, while preserving the more rural, informal character of the current downtown. The Pattern Book includes guidelines and standards for building types, private frontage types, architectural style and detail.

In the four years since the original Pattern Book was adopted, the Village has seen several major renovations and additions, and the construction of a number of new garages, sheds and carports. The 2020 update of the Pattern Book reflects these changes and now includes a separate section to guide the construction of garages and other outbuildings. Another new section, “Lot Patterns,” guides the placement of buildings and parking areas on individual leaseholds. The updated version also includes a number of revisions and additions intended to simplify the approval process and better clarify some of the original standards. The 2020 Pattern Book provides leaseholders and the Lease Committee with clear guidance to ensure quality design in the Village.

Sewanee Pattern Book Volume 3 and the 2024 update represents the learnings and developments of the past 8 years. The focused efforts have been geared towards enhancing user-friendliness for clarity and adapting to the various needs and changes in the town over this period. This latest version introduces greater

flexibility in the choice of materials used, while still upholding the high standards that have been the trademark of the previous editions. Volume 3 vividly brings to life the unique character of Sewanee and includes more local examples of best architectural practices.

Additionally, this Volume of the Pattern Book introduces a catalog of approved architectural house plans created to significantly streamline and simplify the planning process for your home. The plans in this collection not only offers a wide range of options to suit diverse tastes and needs, but it is an invaluable resource for homeowners seeking both inspiration and practical guidance.





# Sewanee Village Regulating Plan

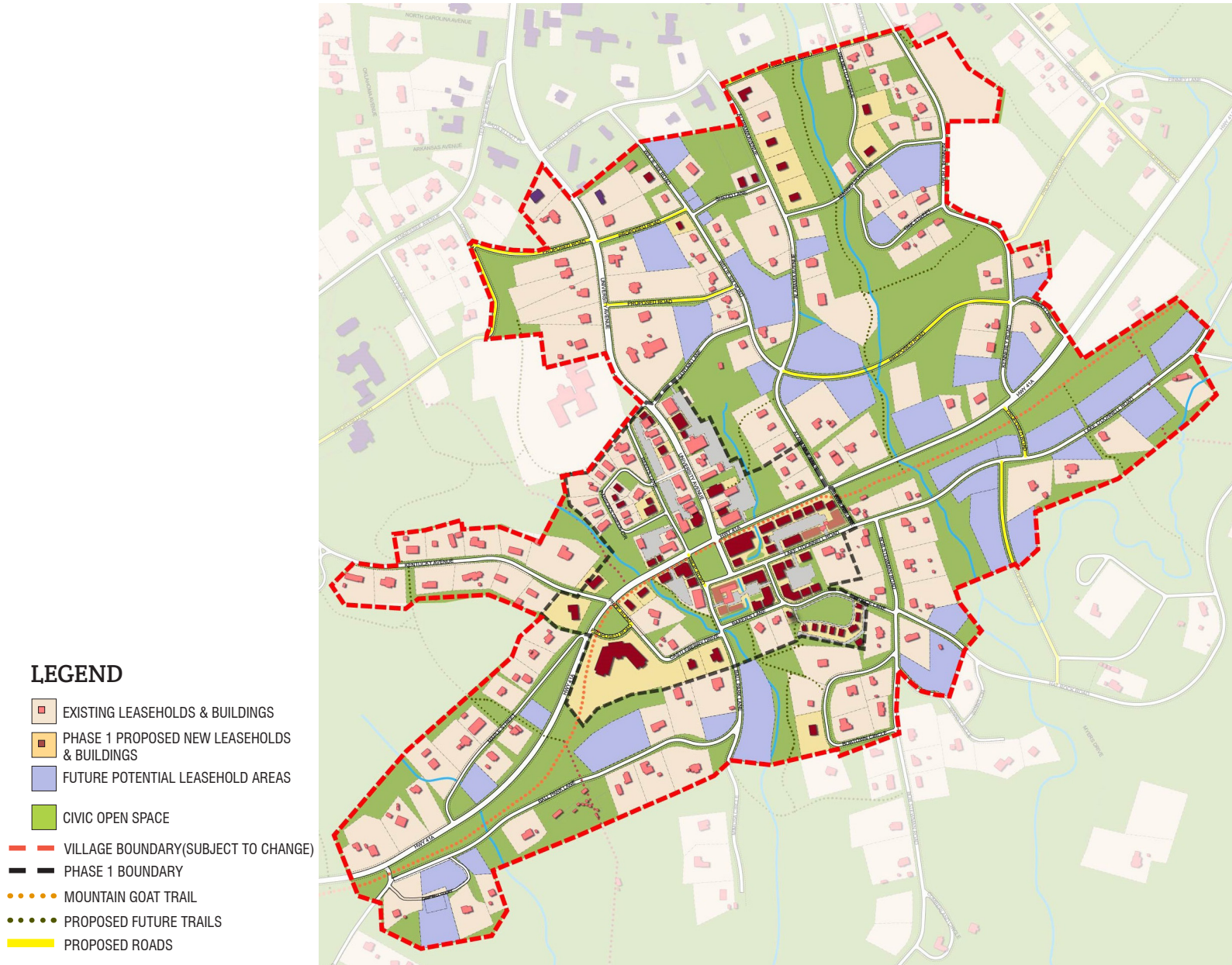



# Sewanee Village Character

Downtown Sewanee is characterized by an eclectic mix of buildings and uses, from a tomato red bike shop to a former commercial laundry converted to a fine dining restaurant. The buildings along University Avenue and the intersection of University and Highway 41A exhibit a mix of traditional styles and elements, sometimes combined in interesting ways. There is little in the way of modern architecture, and the majority of commercial buildings constructed in the 60s, 70s and 80s lack the charm and historical detail of the older buildings. In creating this Pattern Book, we have studied and documented the most-loved structures in Sewanee, and have analyzed and summarized the architectural styles and details of those structures to create guidelines for future construction.





# Preferred Architects

---

The University and the Sewanee Village Planner has compiled a list of preferred architects and designers with the knowledge and skills necessary to design buildings that will improve and enhance the character of the Sewanee Village. This list includes design professionals with a background in traditional architecture and high-quality village planning.

It is strongly recommended that only preferred Architects and Designers work in the Village, including new construction and major renovations and additions. The list of preferred Architects and Designers can be found on the Lease Office website at <https://new.sewanee.edu/offices/university-offices/leases-and-community-relations/>. (Interactive Link)

Architects and designers may submit their portfolios to be considered for inclusion on the Approved List. The Village Planner, the Lease Office, and the Village Project manager will review the portfolios, with special attention given to experience on projects similar to the Sewanee Village.

Minor renovations may be undertaken by professionals not on the preferred Architects and Designers List, at the discretion of the Lease Committee.

# The Sewanee Village Planner

## Function of the Sewanee Village Planner

The Sewanee Village Planner provides planning services to the University of the South for the purposes of ensuring architecture and urban design harmony and adherence to the Sewanee Village Implementation Plan for all new development and redevelopment in the Village and surrounding areas. The Village Planner provides recommendations for the approval or denial of design review applications to the Lease Committee. No structure or improvement shall be erected or altered until these approvals have been obtained by the applicant.

## Scope of Responsibility

The Sewanee Village Planner will review all new construction, major renovations, and additions and will provide recommendations to the Lease Committee for final approval.

## Limitations of Responsibilities

The Village Planner reviews are for aesthetic purposes only and does not assume responsibility for:

- Structural adequacy, capacity, or safety features.
- Non-compatible or unstable soil conditions, erosion etc.
- Compliance with building codes, safety requirements, and governmental laws, regulations, or ordinances.
- Performance or quality of work of contractors.

## Review Policies

The Village Planner reviews the application and either recommends approval, recommends approval with conditions, recommends deferring the application or recommends denial of the application. The recommendation of the Village Planner will be provided to the Lease Committee for their final approval at the monthly Lease Committee meeting.

In all cases, except deferral, one set of documents with comments will be returned to the applicant. Any stage of review that does not receive approval must be resubmitted the following month or any month thereafter.

## Design Review Procedures

Design Review Application requirements, including fee information and checklists, may be obtained from the University Lease Office or by visiting the Sewanee Village Planning website. It is the responsibility of the Leaseholder or Developer to obtain the most up-to-date forms and requirements



# Village Character Districts

The Sewanee Village District has been organized into four “Character Districts,” shown on the map at right. Many of the standards in this Pattern Book, including allowable building and private frontage types, are dependent on the Character District that a leasehold is located in. Please take note of which Character District your leasehold is in before proceeding.

The heart of the Village, located at the intersection of Highway 41A and University Avenue, is considered the “Village Center.” This is where the highest density mixed-use and multi-family development will be found in the form of semi-urban buildings with shopfronts and minimal setbacks.

The area extending a block or so beyond this core, down Highway 41A and up University Avenue, is the “Village Edge.” This area will also include mixed-use and multi-family development but can also include single-family residential buildings like rowhouses. Setbacks will be slightly larger, and a wider variety of private frontage types and building types are allowed.

Most of the remainder of the Village District is characterized as “Village Neighborhood.” This area is primarily single-family residential, with mostly detached homes. Much of this area is already developed, so most new construction will be infill at a scale and character similar to neighboring homes.

There are a few small development sites in the Village that have been identified as “Cottage Court” locations. These compact development clusters will provide opportunities for small houses on small lots, facing onto a common open space. Please refer to the Franklin County Zoning Ordinance for important development standards for Cottage Courts.

Note: The Character District Map is subject to revision. Please contact the University Lease Office for the most up-to-date version.

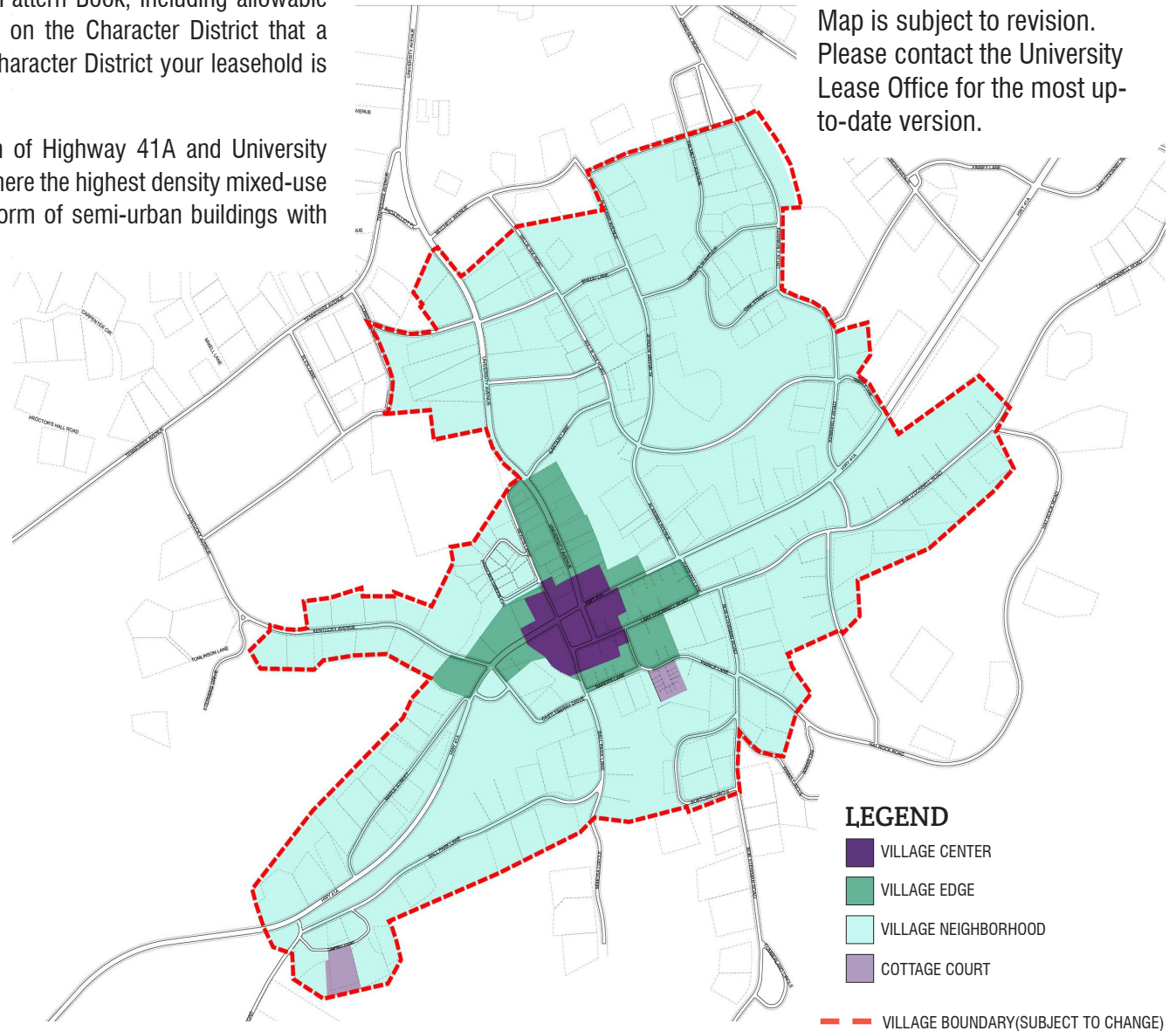

# How To Use This Pattern Book

## How to Use This Pattern Book

It is important to note that the goal of this Pattern Book is not to stifle the creativity of leaseholders, homeowners, business owners, and developers. Rather it is intended to provide a clear framework for architectural styles and “best practices” in architecture and construction, into which homeowners, architects and developers can incorporate customized forms and details.

Compliance with the Pattern Book is based on a number of factors, including the Character District in which the leasehold is located, and whether the applicant is undertaking new construction, renovations, additions, repairs or replacements.

## Step 1: Character Districts

The first step is to identify the Character District that the leasehold is located in. There are four different Character Districts, each described generally in the previous section. A sample map is included on the next page. For an up-to-date map showing the boundaries of each District, contact the Lease Office. Each Character District varies in its allowable building uses, building types, frontage types, setbacks, and other requirements. While the majority of the General Architecture Standards and Architectural Style Standards in the Pattern Book apply to all buildings, regardless of Character Districts, some Districts may have additional standards provided.

Generally:

- The Village Center includes the blocks of downtown that directly surround the intersection between Highway 41A and University Avenue. This is the most prominent and important part of the Village and will undergo a significant change in the coming years, as new mixed use, residential and commercial buildings, and open spaces are constructed.
- The Village Edge includes the blocks surrounding the Village Center, extending up University Avenue, down Highway 41A, and south of the planned civic spaces at the main intersection. This area contains a number of existing commercial and residential buildings that will likely see infill and improvement as the Village Center is developed.

- The Village Neighborhoods are the primarily residential areas within a five- to fifteen-minute walk of the intersection of University Avenue and Highway 41A. Leaseholders in these areas will see gradual improvements to streetscape and architecture, guided by the standards in the Pattern Book.
- The Cottage Courts will be small areas of new construction, intended to provide additional housing options in Sewanee.

## Step 2: Project Use

Identify the use of the building.

### Residential or Mixed-Use/Commercial

- If the building is solely for residential use, the Mixed-Use & Commercial and signage standards are not applicable.
- If the building is for mixed-use or commercial use all relevant standards in the pattern book are applicable.

## Step 3: Project Type

### New Construction

- If the building is new construction in any Character District within the Village boundary, the leaseholder, or developer is required to comply with the standards set forth in this Pattern Book.

### Ordinary Maintenance & Repairs

Ordinary Maintenance or repair of an existing structures is exempt from the standards of this Pattern Books.

# How To Use This Pattern Book

- Keeping a Lot or Building Site, parcel, or Structure in good condition through ongoing minor intervention, undertaken from time to time, in a manner that does not change its external appearance except through the elimination of the usual and expected effects of weathering;
- strengthening or restoring any portion of a structure or improvement to a safe condition, provided no material enlargement results;
- repairing or replacing interior walls, fixtures, wiring or plumbing; or
- repaving driveways, private thoroughfares, internal drives, and parking and loading accommodations,
- replacing exterior windows and siding, and
- painting exterior Structures and fixtures.

## Renovation

- If the building is being completely renovated and is in any Character District within the Village boundary, the leaseholder or developer is required to comply with the standards set forth in this Pattern Book.
- If the building is being partially renovated and is in the Village Center or Village Edge, the leaseholder or developer is required to comply with the standards set forth in this Pattern Book for facades, roofs, or other building elements visible from a thoroughfare (refer to the following section, Illustrated Concepts and Terms, for a definition of a Facade).
- If the building is being partially renovated or added to and is in the Village Neighborhood, the leaseholder or developer may be required to comply with the standards set forth in this Pattern Book if the portion of the building being renovated includes a roof or Facade visible from a thoroughfare. The leaseholder or developer should consult with the University Lease Office prior to submitting an application to determine the level of compliance required.

- If the building is being partially renovated and is in the Village Neighborhood but the portion of the building being renovated does not include a Facade, the leaseholder or developer is encouraged to comply with the standards set forth in this Pattern Book, and is otherwise required to use the same style, materials, and details as the existing building so that the renovation or addition blends seamlessly.

## Additions or Repairs

- If the building is being added to and is in the Village Center or Village Edge, the leaseholder or developer is required to comply with the standards set forth in this Pattern Book if the portion of the building being added to includes a roof, Facade, or other building elements visible from a thoroughfare (refer to the following section, Illustrated Concepts and Terms, for a definition of a Facade).
- If the building is being added to and is in the Village Neighborhood, the leaseholder or developer may be required to comply with the standards set forth in this Pattern Book if the portion of the building being added to includes a roof or Facade that are visible from a thoroughfare. The leaseholder or developer should consult with the University Lease Office prior to submitting an application to determine the level of compliance required.

## Repairs or Replacements

- If a portion of the building is being repaired or replaced, and is in the Village Center, the replacement shall comply with the standards set forth in this Pattern Book.
- If a portion of the building is being repaired or replaced, and is in the Village Edge or Village Neighborhood, the replacement shall be the same material, style, color, and detail as the existing building element, or shall comply with the standards set forth in this Pattern Book.



# How To Use This Pattern Book

---

## Step 4: General Architectural Standards

For new construction, the applicant should familiarize themselves with the standards set forth in the “General Architectural Standards” section of the Pattern Book, which establishes standards for the following:

- Private Frontages;
- Building Types;
- Building Composition & Massing, Configuration, Materials & Details;
- Building Configuration;
- Building Materials and Details;
- Windows, Doors & Openings;
- Roofs;
- Porches, Stoops, Decks & Balconies;
- Chimneys;
- Carriage Houses, Garages & Outbuildings;
- Fences, Walls & Hedges

In the architectural design guidelines, the use of specific materials are prioritized that best align with the character of Sewanee. Initially, the recommended Preferred Materials are chosen for their quality, durability, and compatibility with our design ethos. Additionally, alternative materials listed can be considered, provided they meet specific criteria and conditions. This approach allows for flexibility in material selection while maintaining the high standards of our architectural patterns.

For renovations, additions, or repairs, the applicant should familiarize themselves with the standards appropriate to the project and follow the standards when submitting plans and applications.

## Step 5: Architectural Style Standards

For new construction and improvements to existing buildings, the applicant should refer to the Architectural Style Standards to either choose a style (new construction) or identify the style of the existing building. The applicant shall then follow the standards for style-appropriate massing, details and materials for the building when submitting plans and applications.

# Illustrated Concepts & Terms

The diagrams on this page and the next illustrate a number of important terms and concepts to know when using this Pattern Book.

## Front Yard/Back Yard

Each lot is typically divided into a Front Yard and a Back Yard, which are important in distinguishing the more public parts of the lot from the more private, and in describing the appropriate location for structures and other elements on the lot.

The Front Yard is the area between the front Property Line and a line that is twenty (20) feet behind the Facade of the house.

The Back Yard is the area between the rear Property Line and a line that is twenty (20) feet behind the Facade of the house.

The Front Yard of a corner lot shall include the area between the side of the house and the side Property Line, extending back to the rear Property Line as shown below.

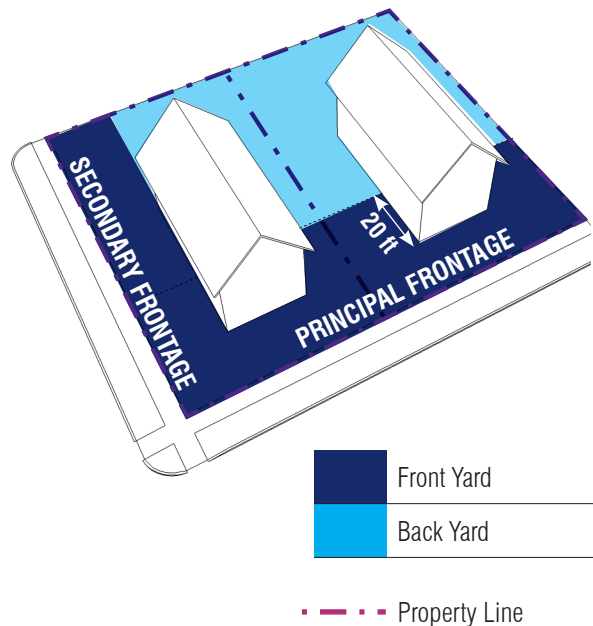

## Frontage, Facades & Elevations

The Principal Frontage is the “front” of the lot, or the side that enfrents the public right-of-way from which the building is addressed, and that which the adjacent building(s) face. Main entrances to all buildings shall be from the Principal Frontage, and the Facade must be parallel to the Principal Frontage (i.e. all buildings must face the street).

The Secondary Frontage applies to corner lots only and describes the “side street” from which the building may have a secondary entrance.

The term “Facade” is used to describe any Elevation of the Principal Building that is oriented toward the Principal or Secondary Frontage. Elevations are all other sides of the building. To summarize, all Facades are Elevations but not all Elevations are Facades.

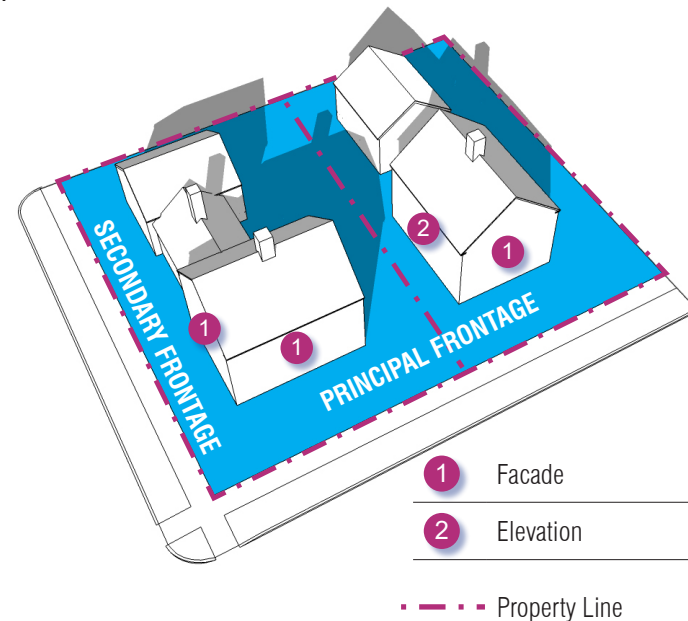



# Illustrated Concepts & Terms

## Principal Building vs Outbuilding

Each lot in the Sewanee Village shall have no more than one (1) Principal Building and one (1) Outbuilding. The Principal Building shall be oriented to the Principal Frontage (the public thoroughfare on which the lot enfronts). The Outbuilding shall be in the Back Yard as described in the diagram on the previous page.

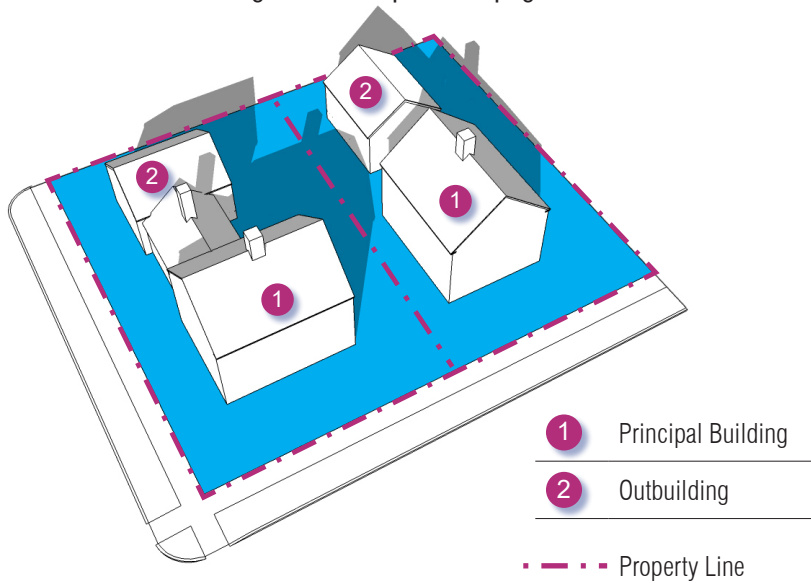

## What is an Outbuilding?

Outbuildings include garages, carriage houses, carports, accessory dwelling units, sheds, and other buildings ancillary to the Principal Building, whether or not they are attached to the Principal Building. A small, detached structure such as a potting shed or gazebo (no larger than 10' by 10') may be permitted as a second outbuilding with the recommendation of the Village Planner and the approval of the Lease Committee. The location of such structure is subject to the review of the Village Planner and the approval of the Lease Committee.

## Setbacks

The placement of all buildings on a lot shall be described in terms of the Front Setback, the Rear Setback, and the Side Setback. Setback requirements will be provided to each Leaseholder by the Lease Office.

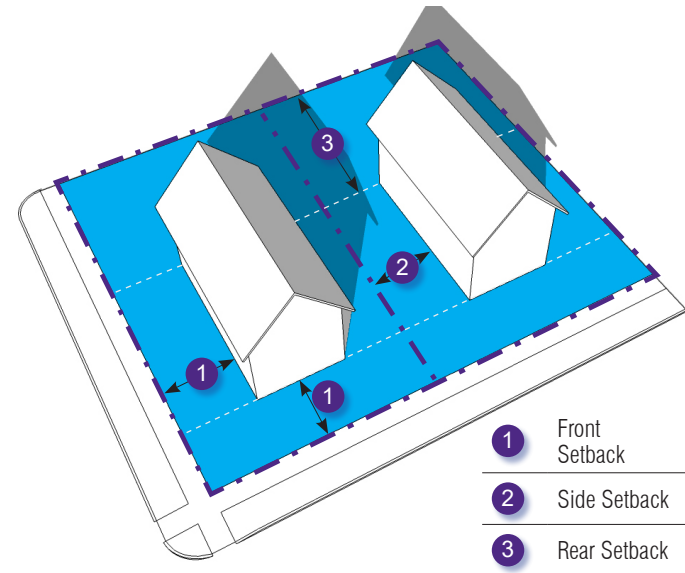

# Village Edge Lot Patterns

## Village Edge - Attached

### Lot Width

Minimum	18 ft.
Maximum	100 ft.

### Principal Building

Front Setback	10 ft. min. 30 ft. max.*	<b>A</b>
Front Encroachment	If building has a Porch, Stoop, Dining Yard, Commercial Porch or Gallery, it may extend into the Front Setback*	
Side Setback	0 ft. min.	<b>B</b>
Rear Setback	3 ft. min. or 15 ft. min. from the centerline of the rear alley (if lot is alley loaded); whichever is larger	<b>C</b>
Building Height	3 stories max. for Multifamily or Mixed Use Buildings; otherwise 2 stories max.	

### Outbuilding (allowed in the "Outbuilding Zone" as shown)

Front Setback	20 ft. min. behind Facade of house, in Backyard
Side Setback	0 ft. min.
Rear Setback	5 ft. min.
Building Height	2 stories max.

\* 30 ft. max. setback is not shown in diagram.

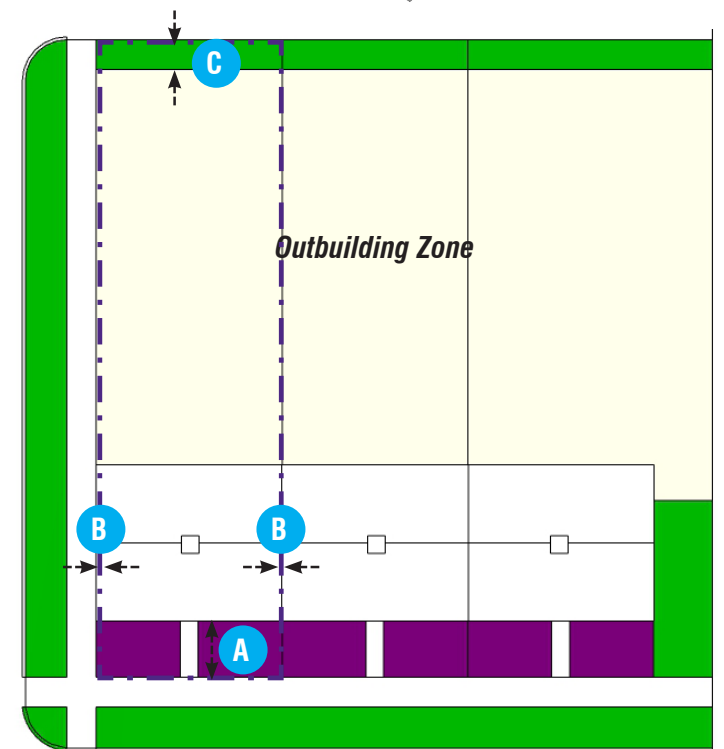
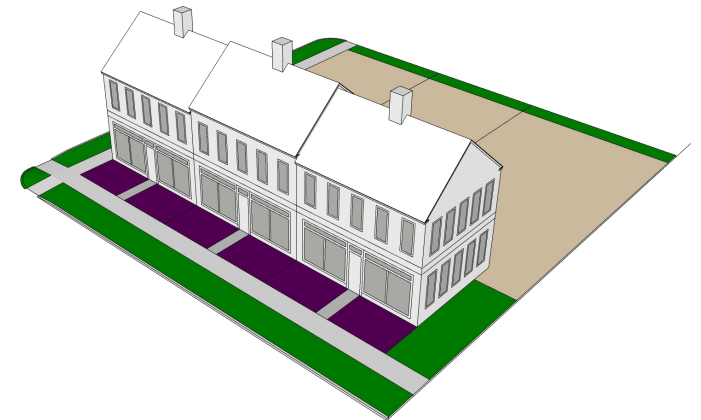



# Village Edge Lot Patterns

## Village Edge - Detached

### Lot Width

Minimum	25 ft.
Maximum	100 ft.

### Principal Building

Front Setback	10 ft. min.* 30 ft. max.	<b>A</b>
Front Encroachment	If building has a Porch, Stoop, Dining Yard, Commercial Porch or Gallery, it may extend into the Front Setback*	
Side Setback	5 ft. min.	<b>B</b>
Rear Setback	3 ft. min. or 15 ft. min. from the centerline of the rear alley (if lot is alley loaded); whichever is larger	<b>C</b>
Building Height	3 stories max. for Multifamily or Mixed Use Buildings; otherwise 2 stories max.	

### Outbuilding (allowed in the "Outbuilding Zone" as shown)

Front Setback	20 ft. min. behind Facade of house, in Backyard
Side Setback	5 ft. min.
Rear Setback	5 ft. min.
Building Height	2 stories max.

\* 10 ft. min. setback is not shown in diagram.

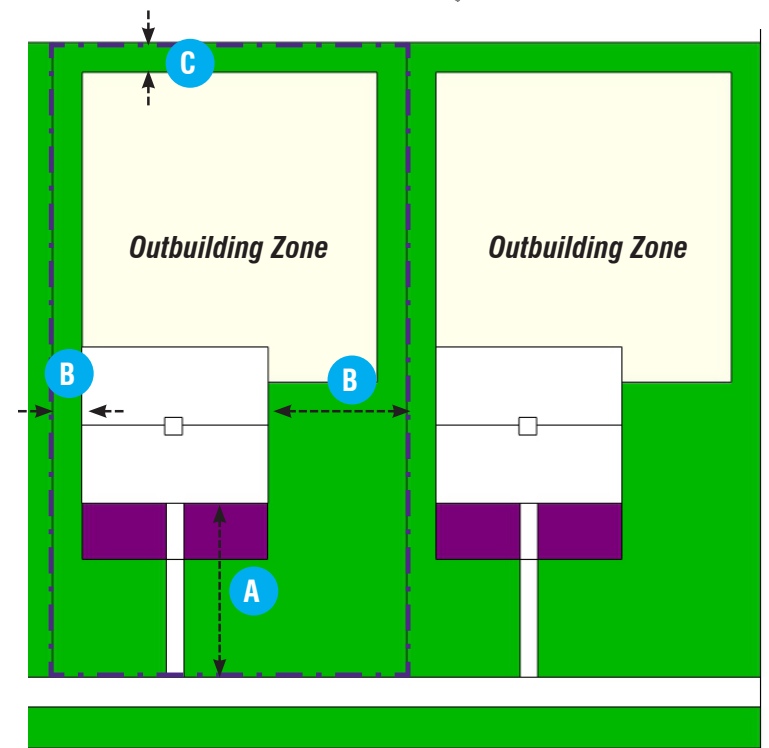
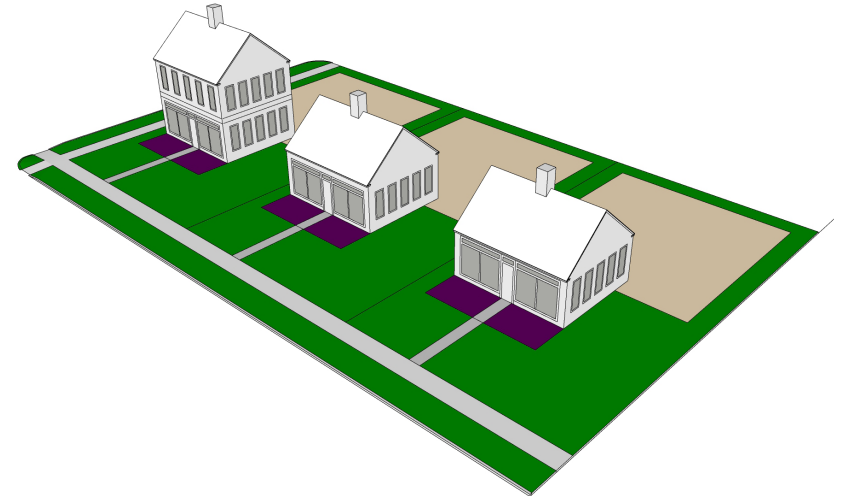

# Village Neighborhoods

## Lot Patterns

### Village Neighborhood - Attached

#### Lot Width

Minimum	18 ft.
Maximum	24 ft.

#### Principal Building

Front Setback	20 ft. min. 60 ft. max.*	<b>A</b>
Front Encroachment	If building has a Porch, Stoop, Dining Yard, Commercial Porch or Gallery, it may extend into the Front Setback*	
Side Setback	0 ft. min.	<b>B</b>
Rear Setback	3 ft. min. or 15 ft. min. from the centerline of the rear alley (if lot is alley loaded); whichever is larger	<b>C</b>
Building Height	3 stories max. for Multifamily Buildings; otherwise 2 stories max.	

#### Outbuilding (allowed in the "Outbuilding Zone" as shown)

Front Setback	20 ft. min. behind Facade of house, in Backyard
Side Setback	0 ft. min.
Rear Setback	5 ft. min.
Building Height	2 stories max.

\* 60 ft. max. setback is not shown in diagram.

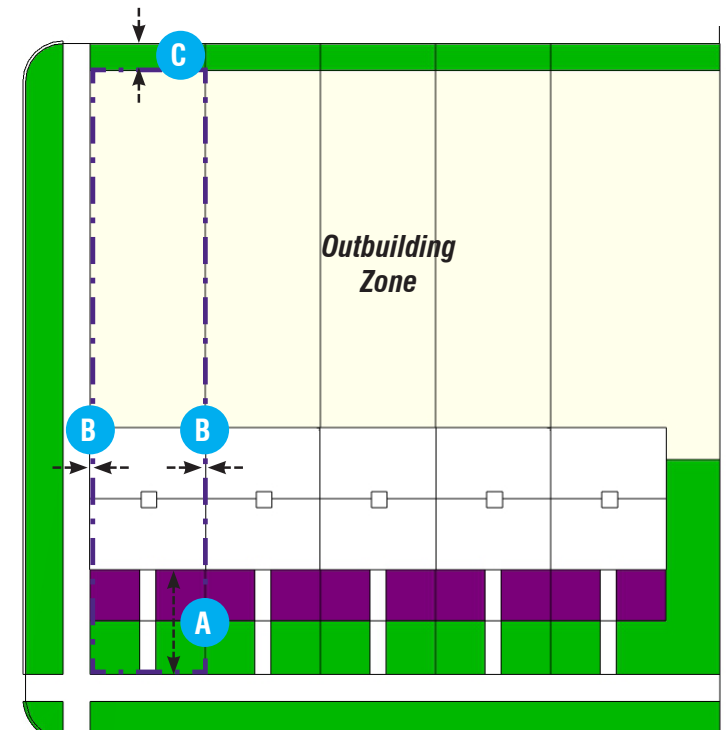

# Village Neighborhoods

## Lot Patterns

### Village Neighborhood - Detached

#### Lot Width

Minimum	50 ft.
Maximum	100 ft.

#### Principal Building

Front Setback	20 ft. min.* 60 ft. max.	<b>A</b>
Front Encroachment	If building has a Porch, Stoop, Dining Yard, Commercial Porch or Gallery, it may extend into the Front Setback*	
Side Setback	10 ft. min.	<b>B</b>
Rear Setback	3 ft. min. or 15 ft. min. from the centerline of the rear alley (if lot is alley loaded); whichever is larger	<b>C</b>
Building Height	3 stories max. for Multifamily Buildings; otherwise 2 stories max.	

#### Outbuilding (allowed in the "Outbuilding Zone" as shown)

Front Setback	20 ft. min. behind Facade of house, in Backyard
Side Setback	5 ft. min.
Rear Setback	5 ft. min.
Building Height	2 stories max.

\* 20 ft. min. setback is not shown in diagram.

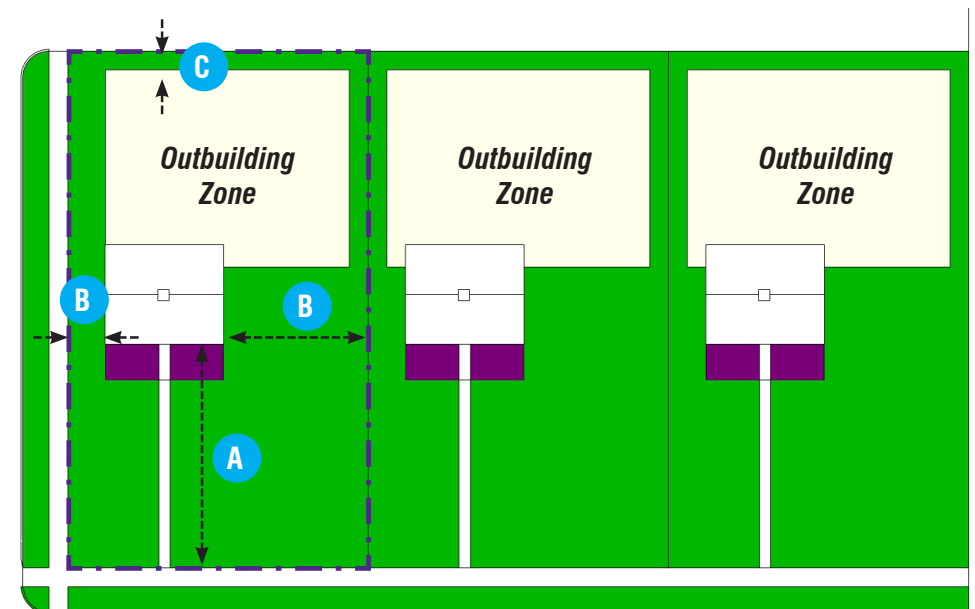
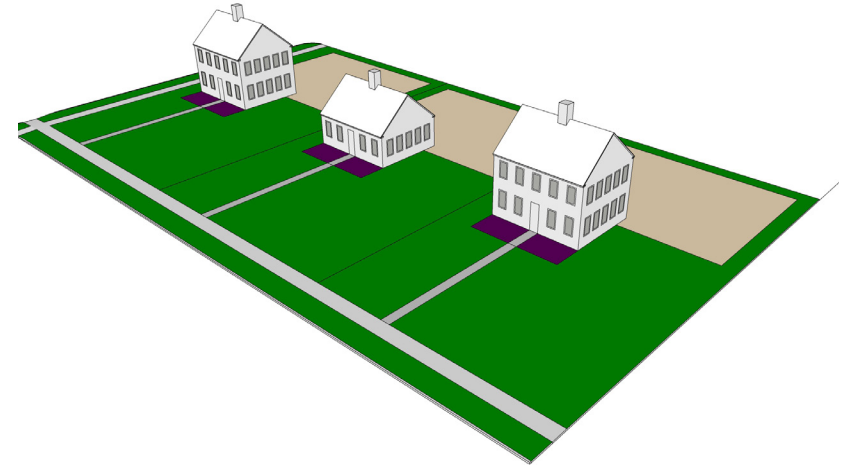



# Cottage Court Lot Patterns

## Cottage Court - Attached

### Lot Width

Minimum	18 ft.
Maximum	40 ft.

### Principal Building

Front Setback	0 ft. min.* 15 ft. max.	<b>A</b>
Front Encroachment	If building has a Porch or Stoop, it may extend into the Front Setback*	
Side Setback	0 ft. min.	<b>B</b>
Rear Setback	3 ft. min. or 15 ft. min. from the centerline of the rear alley (if lot is alley loaded); whichever is larger	<b>C</b>
Building Height	2 stories max.	

### Outbuilding (allowed in the "Outbuilding Zone" as shown)

Front Setback	20 ft. min. behind Facade of house, in Backyard
Side Setback	0 ft. min.
Rear Setback	5 ft. min.
Building Height	2 stories max.

\* 0 ft. min. setback is not shown in diagram. If Principal Building is placed at 0 ft. setback, there will be no Front Encroachment allowed for Porches or Stoops.

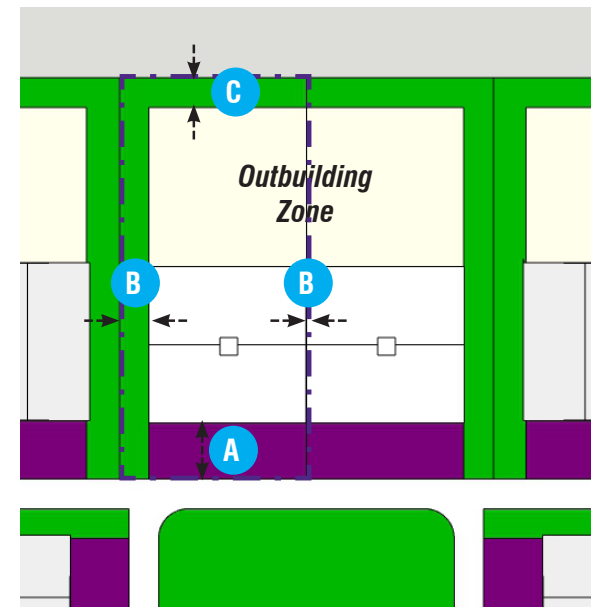

# Cottage Court Lot Patterns

Cottage Court - Detached	
<b>Lot Width</b>	
Minimum	25 ft.
Maximum	40 ft.
<b>Principal Building</b>	
Front Setback	0 ft. min.* 15 ft. max. <span style="float: right;">A</span>
Front Encroachment	If building has a Porch or Stoop, it may extend into the Front Setback* <span style="float: right;">B</span>
Side Setback	5 ft. min. <span style="float: right;">B</span>
Rear Setback	3 ft. min. or 15 ft. min. from the centerline of the rear alley (if lot is alley loaded); whichever is larger <span style="float: right;">C</span>
Building Height	2 stories max.
<b>Outbuilding (allowed in the "Outbuilding Zone" as shown)</b>	
Front Setback	20 ft. min. behind Facade of house, in Backyard
Side Setback	5 ft. min.
Rear Setback	5 ft. min.
Building Height	2 stories max.

\* 0 ft. min. setback is not shown in diagram. If Principal Building is placed at 0 ft. setback, there will be no Front Encroachment allowed for Porches or Stoops.

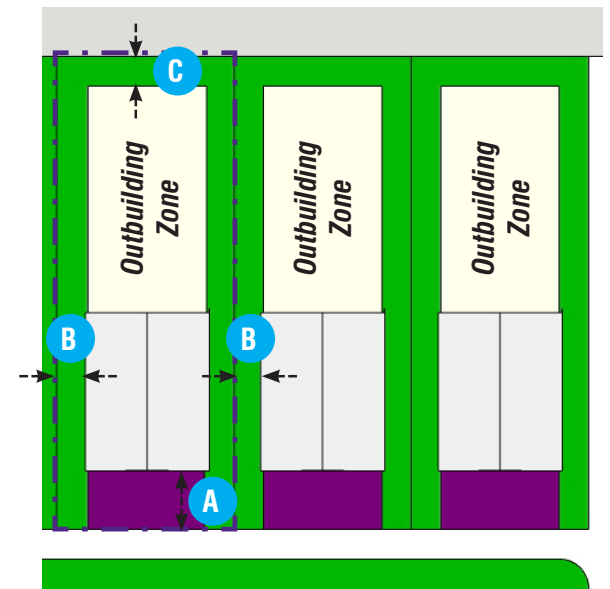
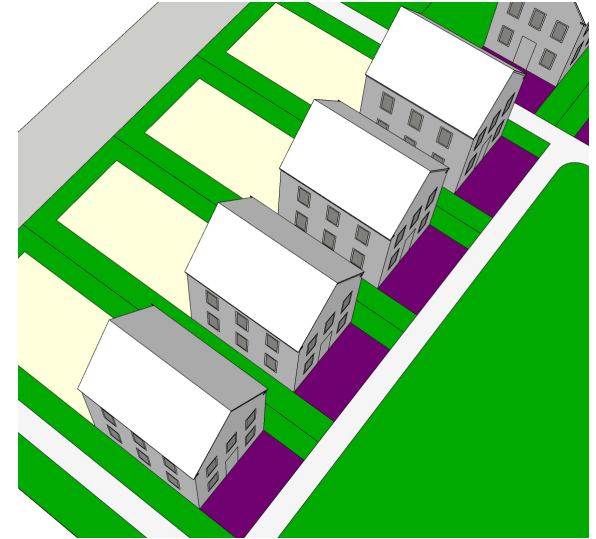

# Carriage House/Garage Placement Lot Patterns

**Front-Loaded, Front-Facing  
Attached Outbuilding**

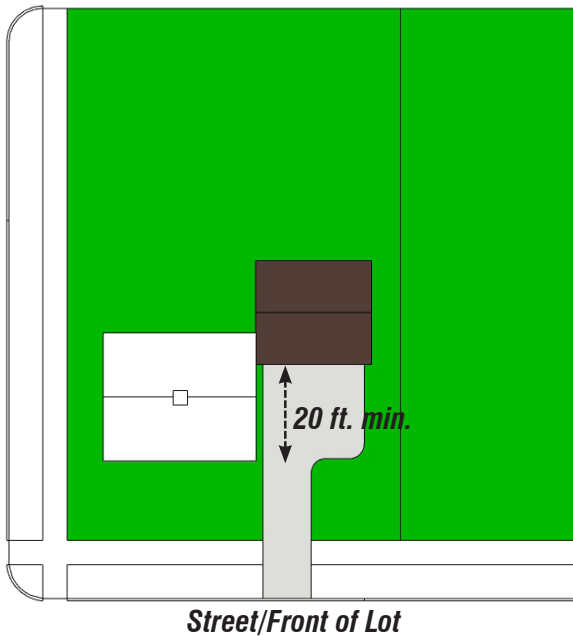

**Front-Loaded, Front-Facing  
Detached Outbuilding**

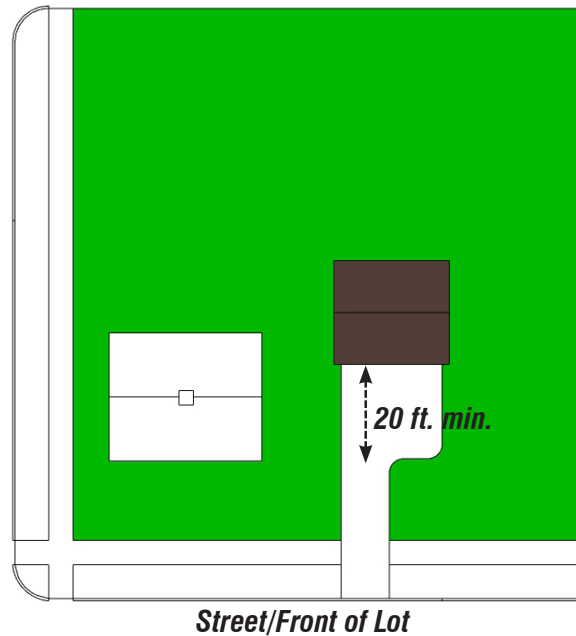

**Front-Loaded, Side-Facing  
Attached Outbuilding**

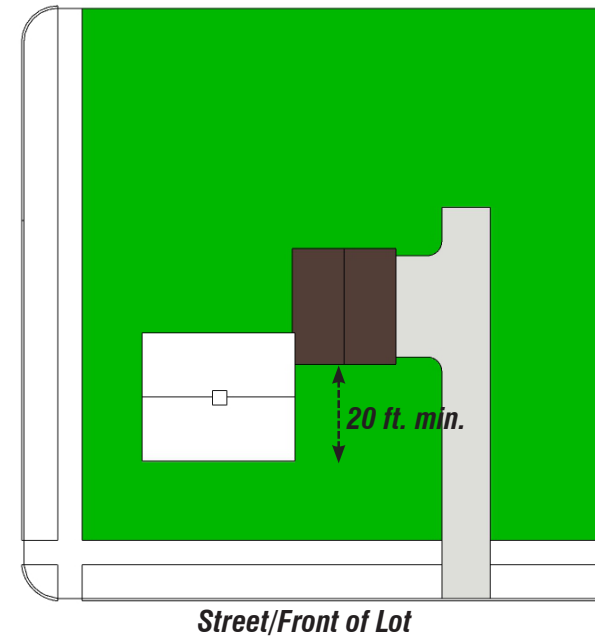

Outbuilding faces street and is set back a minimum of 20 ft. from the Facade, per requirements.

Outbuilding faces street and is set back a minimum of 20 ft. from the Facade, per requirements.

Outbuilding faces the side of the lot and is set back a minimum of 20 ft. from the Facade, per requirements.



# Carriage House/Garage Placement Lot Patterns

**Front-Loaded, Side Facing  
Detached Outbuilding**

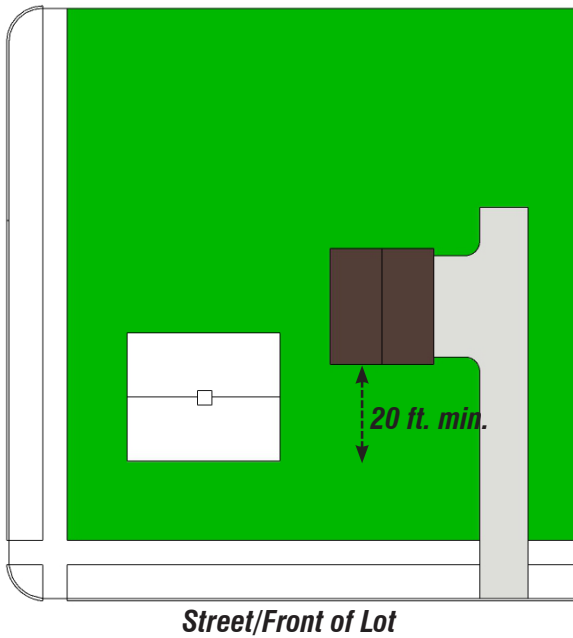

Outbuilding faces the side of the lot and is set back a minimum of 20 ft. from the Facade, per requirements.

**Rear-Loaded, Rear-Facing  
Attached Outbuilding**

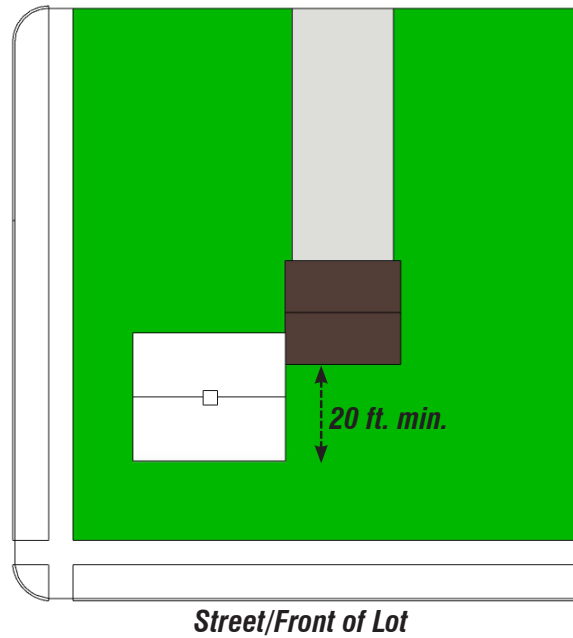

Outbuilding faces the rear of the lot and is accessed from a rear lane or alley. The Outbuilding is set back a minimum of 20 ft. from the Facade, per requirements.

**Rear-Loaded, Rear-Facing  
Detached Outbuilding**

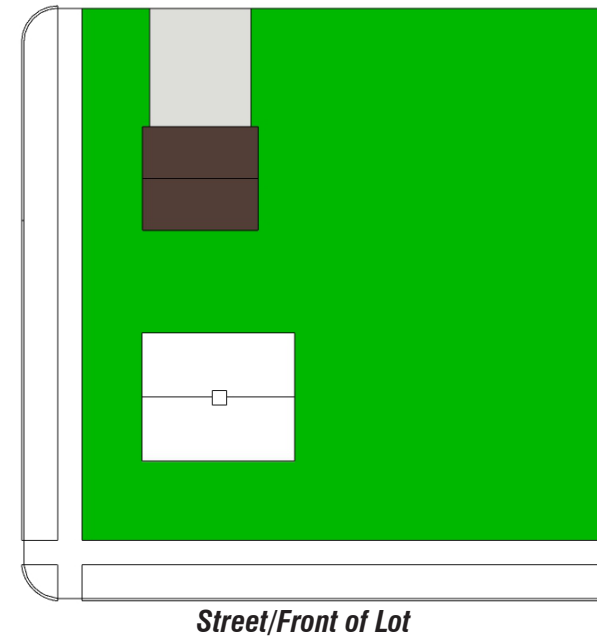

Outbuilding faces the rear of the lot and is accessed from a rear lane or alley. The Outbuilding is set back a minimum of 20 ft. from the Facade, per requirements.

# Residential Architectural Standards

## Private Frontage Types

The Private Frontage is the area between the building Facade and the public right-of-way, and can take on a number of configurations, depending on the type of building and primary use of the building. The following table illustrates eight different types of Private Frontage types that are appropriate to Sewanee, along with the Character Districts each are permitted in.

Frontage Type			Permitted Districts
		<p><b>Common Yard:</b> A planted Frontage wherein the Facade is set back substantially from the Frontage Line. The front yard created remains unfenced and is visually continuous with adjacent yards, supporting a common landscape. This type may be used for residential use only.</p>	<p><b>Village Neighborhood</b></p>
		<p><b>Porch:</b> A planted Frontage wherein the Facade is set back from the Frontage Line with an attached porch permitted to encroach into the Front Setback. This may be used with or without a fence to maintain thoroughfare spatial definition. This type may be used for residential use only. See “Commercial Porch” for non-residential porch applications.</p>	<p><b>Village Edge Village Neighborhood Cottage Court</b></p>

# Residential Architectural Standards

## Private Frontage Types





Frontage Type	Permitted Districts
 	<p><b>Stoop:</b> A Frontage wherein the Facade is aligned close to the Frontage Line with the first story elevated from the sidewalk sufficiently to secure privacy for the windows. The entrance is usually an exterior stair and landing. This type is recommended for ground-floor residential use.</p> <p><b>Permitted Districts</b>  <b>Village Center</b>  <b>Village Edge</b>  <b>Village Neighborhood</b>  <b>Cottage Court</b></p>
 	<p><b>Gallery:</b> A Frontage wherein the Facade is aligned close to the Frontage line with an attached cantilevered shed or a lightweight colonnade. This type is intended for buildings with ground floor commercial or retail uses, and the Gallery may not encroach into the right-of-way.</p> <p><b>Permitted Districts</b>  <b>Village Center</b></p>





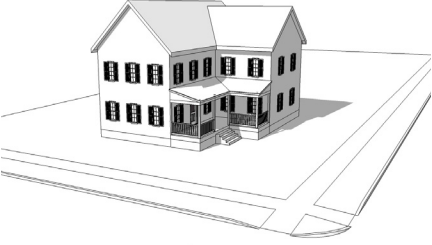

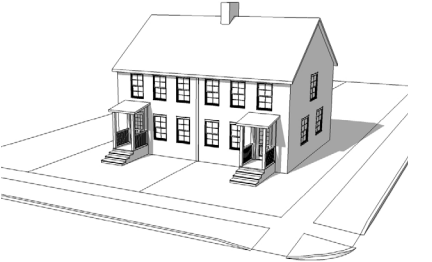
# Residential Architectural Standards

## Building Types

The following table illustrates the seven different classifications of Building Types considered appropriate for construction in Sewanee. Within each Building Type category, buildings may vary widely in character, style, massing, and configuration. The table provides a list of permitted Character Districts for each Building Type, as well as the permitted Frontage Types for that building.

Building Type			Permitted Districts	Permitted Frontage Types	Additional Information
		<p><b>House:</b> A detached building that may be shared with an Outbuilding in the backyard. This building type typically incorporates a single residential unit.</p>	<p><b>Village Center</b> <b>Village</b> <b>Neighborhood</b></p>	<p><b>Common Yard</b> <b>Porch</b> <b>Stoop</b></p>	<p>None</p>
		<p><b>Duplex:</b> A small to medium sized building that consists of two attached units, with separate entrances at least one of which faces the thoroughfare. Both of the units, side-by-side, front-to-back or over-and-under, are contained within a single building massing. This building type sits on a small to medium sized lot that may be shared with an Outbuilding in the backyard.</p>	<p><b>Village Edge</b> <b>Village</b> <b>Neighborhood</b> <b>Cottage Court</b></p>	<p><b>Common Yard</b> <b>Porch</b> <b>Stoop</b></p>	<p>At least one unit shall have an individual entry on the primary Frontage.</p>

Building Type			Permitted Districts	Permitted Frontage Types	Additional Information
		<p><b>Rowhouse:</b>                      A collection of very narrow to medium sized attached buildings that consists of side-by-side units with individual entries facing the thoroughfare. This type shares at least one-party wall with another building of the same type and occupies the full Frontage Line.</p>	<p><b>Village Center</b>  <b>Village Edge</b>  <b>Village</b>  <b>Neighborhood</b>  <b>Cottage Court</b></p>	<p><b>Porch</b>  <b>Stoop</b></p>	<p>Each rowhouse grouping shall have 3-8 attached rowhouses</p>
		<p><b>Multifamily:</b>                      A building that consists of side-by-side and/or horizontally stacked units, typically with one or more shared entries.</p>	<p><b>Village Edge</b>  <b>Village</b>  <b>Neighborhood</b></p>	<p><b>Common Yard</b>  <b>Porch</b>  <b>Stoop</b></p>	<p>Minimum of 3 units per building. Upper floors shall be accessed by a common entry.</p>

# Building Composition & Massing

## Building Massing

The “primary massing” of a building refers to the main body of the structure, onto which additions or “secondary massings” may be added. In the large house example to the right, the “primary massing” is the portion of the house highlighted in yellow, while the wings or additions on either side are considered “secondary massing.” Most buildings in Sewanee will consist of a single, primary massing, and any secondary massing should be harmonious and well-balanced.

## Building & Facade Composition

The windows, doors, and architectural elements of each floor of a building shall align horizontally and vertically, as shown in the example at right. Symmetry is not required, as long as elements are well-balanced.

The main entrance of a structure must be in the Facade of the Principal Frontage.

If the building has a Shopfront Frontage at the corner, the main entrance may be at the Principal Frontage or at the corner.

Blank walls are prohibited at Frontages. Windows and doors should comprise at least 20% of all Frontages, with the exception of Shopfront Frontages, which should be a minimum of 70%.

## Maintenance & Repair

All structural and decorative elements of each building and each component thereof shall be properly maintained and repaired. Missing, rotten, deteriorated or weakened elements shall be replaced to match the original materials and construction of the building, unless the building is located in the Village Center, in which case the replacement elements shall comply with the Pattern Book standards (see “How To Use This Pattern Book”).





# General Architectural Standards

## Building Configuration

### Configuration

Walls and gables of Outbuildings shall match the form, color, materials, and details of the associated Principal Building.

Additions and/or secondary massings may be the same material as the primary massing or a lighter material (for example, a brick house may have a siding addition but never vice versa).

Columns, piers, and arches shall be detailed and proportioned in a manner that is historically accurate and consistent with the architectural style of the building.

The space between columns shall be vertically proportioned, meaning the horizontal distance between columns shall be less than the height of the column (see illustration at right).

An articulated cornice shall be provided where the top of a building wall meets the roof (see illustration at right).

On buildings with pitched roofs, the cornice may be comprised of a gutter and fascia board under the eave.

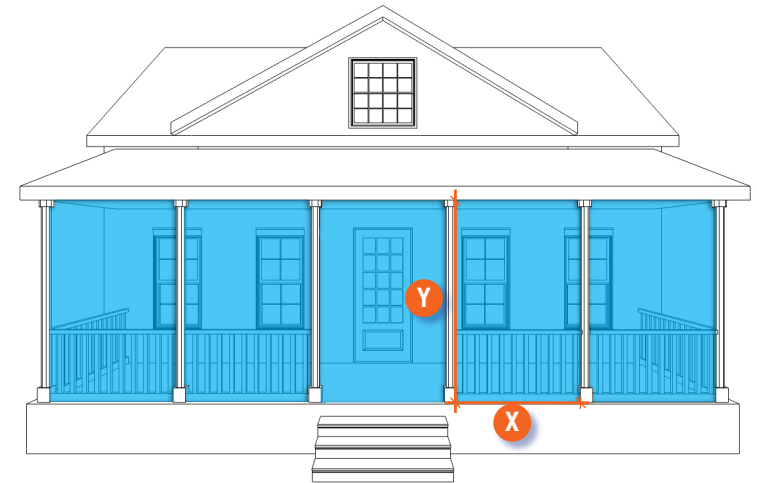

Space between columns

$$X < Y$$

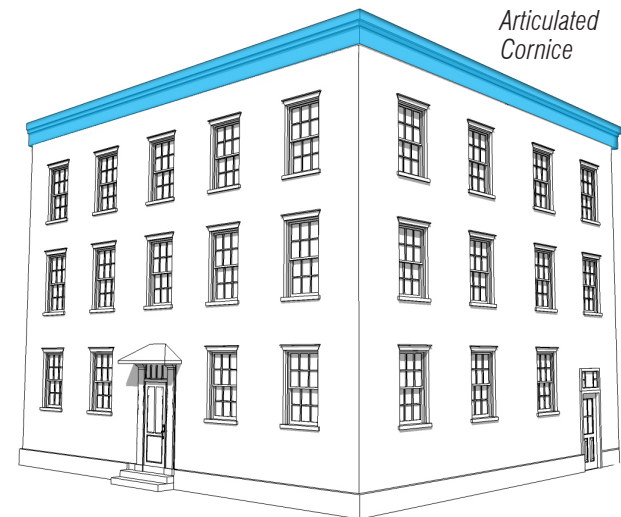

# General Architectural Standards

## Building Materials & Details

### Building Materials:

In order to maintain the current character of Sewanee's downtown area, the preferred exterior materials for the majority of buildings in the Village are wood siding and metal roofing. Refer to the "Architectural Style Standards" section of the Pattern Book for specific material requirements by Architectural Style. Additional material requirements for roofs, trim, and other details are included in the sections that follow:

Wall materials shall be:

#### Preferred Material

- Horizontal wood or smooth cementitious siding;
- Painted or opaque-stained (on both sides) smooth-cut wood shingle or smooth cementitious shingle (as architecturally appropriate, primarily in Victorian applications);
- Wood tongue and groove;
- Wood clapboard siding;
- Wood board-and-batten siding (boards shall be no wider than 12" and battens shall be no more than 2");
- Wood or cementitious shingles;
- Painted or unpainted brick of a standard "Roman" size and horizontal bond pattern unless otherwise permitted by the Village Planner;
- Smooth cementitious siding with all exposed surfaces painted; or
- Local sandstone (if a synthetic stone that is indistinguishable from the local sandstone found on the University of the South campus is available, it will be considered by the Village Planner);

Columns and post materials shall be:

- Painted or unpainted brick;
- Natural stone;
- Painted or opaque stained wood; or
- Painted synthetic wood.

Exterior trim shall be indistinguishable from wood when painted, and shall be:

- Natural wood;
- Fiber-reinforced cementitious trim; or
- PVC-based products.

Foundation walls, retaining walls, arches, piers, and pilings shall be finished in:

#### Preferred Material

- Natural stone veneer,
- Painted or unpainted brick veneer of a standard "Roman" size; or
- Stucco.

#### Acceptable Material

- Painted split-faced block

In the absence of a continuous foundation wall, the undercroft (space between piers and pilings) may be enclosed with natural wood lattice, painted to match the foundation. The pattern of such lattice is subject to review. See the image below as an example.



## Prohibited Materials

Several prohibited materials are specifically addressed in this section for the sake of clarity. This does not mean that only those materials addressed here are prohibited. All materials not previously listed as a Permitted Material are prohibited unless otherwise approved by the Village Planner and the Lease Committee.

- Unfinished smooth-face concrete block (commonly referred to as “cinder block” or “CMU”) shall not be used as an exterior material except in certain areas of the Village Neighborhood Zone, as determined by the Village Planner.
- Artificial stone is not permitted anywhere in the Village Zone.
- Cedar shakes or shingles are not a regionally appropriate building material in Sewanee and their use is prohibited.



# General Architectural Standards

## Building Materials & Details

### Building Colors

Building walls shall be one color per material used.

One of the defining elements of the Sewanee Village character is the variety of bold colors used on buildings in the Village Center. New Village Center buildings should utilize bold, but traditional color choices in their building walls and trim, with the approval of the Village Planner and Lease Committee. Walls of adjacent buildings shall be of a visibly different color; that is to say no building should be painted the same color as that of their neighbor. In addition, it is preferable that no building that is painted a “bold” color (red, yellow, or non-neutral shades of blue or green) be visible from any vantage point in the Village as another building of the same color.

### Combining Building Materials:

No more than two materials should be used on a building wall. If two different materials are used, the material change should be horizontal, with the heavier material below the lighter. The image at right shows a building with the lighter material (siding) over a heavier material (stucco over brick).

Walls of both Facades of a corner building shall be made of the same materials and similarly detailed.





# General Architectural Standards

## Building Materials & Details

### Foundation Wall Details:

Foundation walls shall extend a minimum of 6" and a maximum of 36" above average grade (see illustration at right).

Surface-applied waterproofing shall not be visible above finished grade (see illustration at right).

### Trim Details:

Trim shall not exceed 5/4" in depth or 6" in width at corners and around openings, except at the front entrance, which is allowed to be any width or configuration.

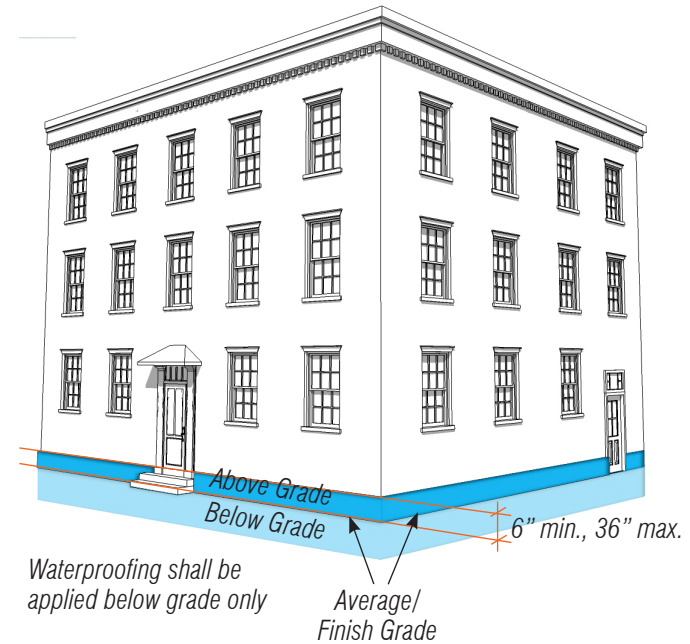

# General Architectural Standards

## Windows & Openings

### Window and Opening Configuration

Window and opening configurations shall be consistent with the architectural style of the building in which they are used. Refer to the “Architectural Style Standards” section of the Pattern Book for additional information.

All windows, with the exception of shopfronts, shall be square or vertical in proportion, meaning that the height is greater than or equal to the width.

Windows shall be uniform in size or proportion, provided that windows are allowed to be smaller on the top portion of the building (see illustration at top right).

With the exception of Shopfronts, windows shall be no closer than 2’ from the corners of the building (see illustration below).

Lintels and sills on adjacent windows within the same story shall be aligned (see illustration at bottom right).



### Window Types

Windows in Facades shall be operable, sashed, casement or awning windows, except for windows of Shopfront Frontages.

If used, storm windows shall be integral with the window.

Window screens, if provided, shall cover the entire operable portion of the window.

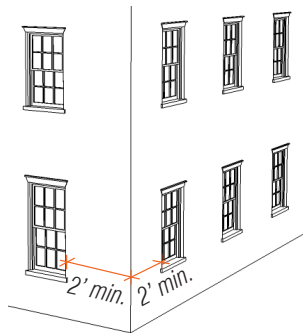

*On each building story, lintels and sills are aligned*

# General Architectural Standards

## Windows & Openings

### Preferred Materials

Except for the glazing and hardware, windows shall be made of PVC, wood, or aluminum- or vinyl-clad wood.

Screen frames shall be unpainted aluminum or the same color as the associated window.

Glass in windows shall be low-e, colorless, and transparent with the exception of stained glass as architecturally appropriate and as specifically approved by the Village Planner.

### Acceptable Materials

Vinyl window frames with coordinating trim color and wider trim widths are permitted for residential applications.

### Prohibited Materials

Tinted, frosted, mirrored, painted or opaque glass and glass blocks are not allowed within Facades.

Aluminum storm windows or doors are not allowed on Facades in the Village Center or Village Edge.

### Shutters

Shutters, if provided, shall be made of painted or synthetic wood, shall be or appear to be fully operational with all necessary hardware, and shall be sized, shaped, and proportioned to match the associated openings (see images at right).

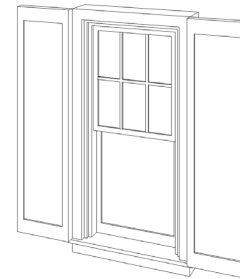

*Single window with shutters  
one-half of the window width*

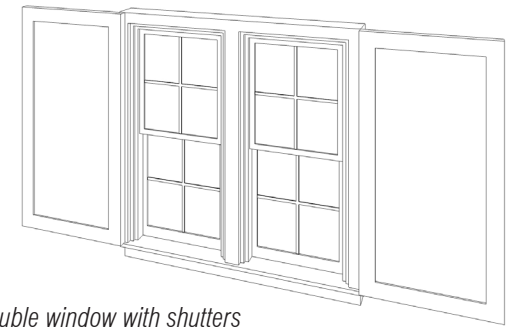

*Double window with shutters  
the width of each window*



# General Architectural Standards

## Windows & Openings

### Divided Lites & Lite Patterns

Divided lites of windows within Facades, if any, shall be true divided lites (individual glass panes) or simulated divided lites fixed on the exterior surface of the windowpane with spacer bars to cast a shadow. Panes shall be square or vertical in proportion, meaning that the height of each pane is taller than the width (illustration below).

Divided Lites

$$X < Y$$

or

$$X = Y$$

Vertical or  
square in  
proportion

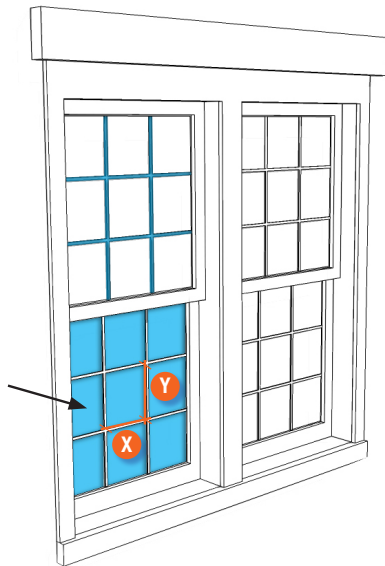

No - "Grid between glass"  
or "grill between glass"  
windows are not allowed.



Yes - Simulated divided lites  
are affixed to the exterior  
of the glass on both the  
inside and outside of the  
window, with a spacer bar  
in between.



Yes - True divided lites are  
individual smaller panes of  
glass.



Photos: Marvin



# General Architectural Standards

## Windows & Openings

### Divided Lites & Lite Patterns (continued)

Divided lite patterns shall be appropriate to the architectural style of the building and are typically one of the patterns shown at right. The numbers provided reference the number of panes on the upper and lower part of the window, which vary according to different architectural styles.



White, Vinyl, one-over-one, double hung window from the ViWinTech2100 Series with full screen.

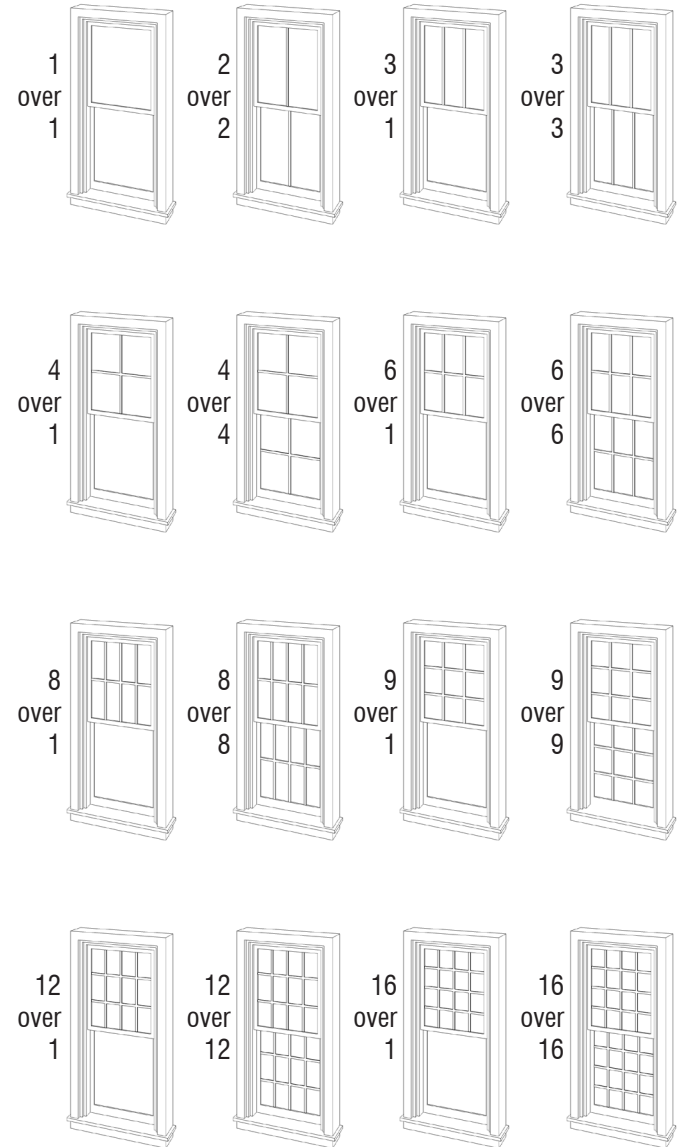

# General Architectural Standards

## Windows & Openings

### Details

Windows shall be consistent with the architectural style of the building in which they are used. Refer to the “Architectural Style Standards” section of the Pattern Book for additional information.

In Facades, when viewed in cross-section, the centerline of the window sash shall align within the centerline of the wall or be closer to the interior (see illustration at right). Flush-mounted and projecting windows are prohibited.

Windows shall be fully articulated with a lintel, face frame and drip mold.

Any lintels of stone or pre-cast concrete shall extend horizontally beyond the window opening dimension by an amount equal to the height of the lintel. Any brick soldier lintels shall extend one brick beyond the opening.

Windows in wood- or cementitious- sided buildings shall have a flat casing, 5/4 inch in depth.

Brickmold window casing shall be used in masonry walls.

Sidelights shall not exceed 12” in width.

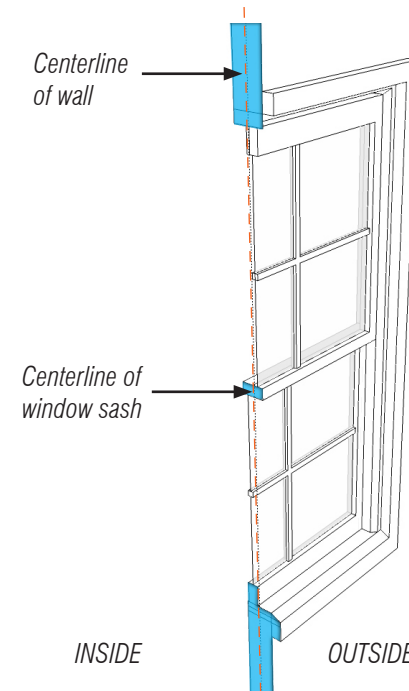

# General Architectural Standards

## Windows & Openings

### Details (continued)

Windows may be paired or grouped if separated by a 4"-6" mullion (see illustration at right). Otherwise, windows shall be spaced no less than twelve (12") inches apart. Window spacing shall be proportional, and if shutters are to be used, shall allow enough space between windows for opened shutters.

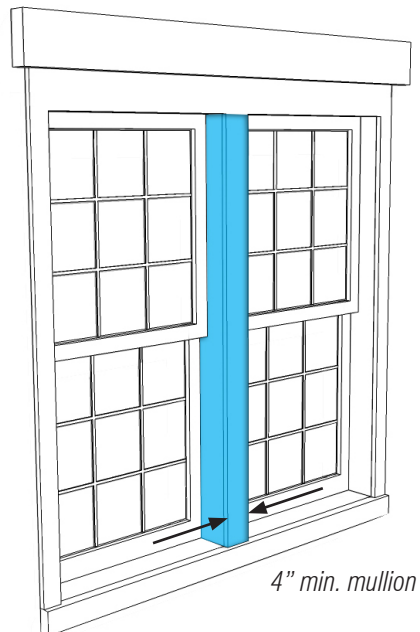

*At right: Windows spaced far enough apart to accommodate opened shutters*

*At right: Grouping of windows separated by mullions*



# General Architectural Standards

## Windows & Openings

### Bay Windows

Bay Windows shall extend all the way to the ground or be provided with brackets, which appear to support the bay window (see illustration at right).

Bay windows shall be a maximum of 4' deep (see illustration at right).

Bay windows shall be built of wood or other material indistinguishable from wood when painted.

### Maintenance & Repair

All windows shall be kept in good repair. Any repairs or replacements shall match the originals, with respect to materials and design unless otherwise approved by the Village Planner.

Windows within a street-facing Façade shall not be removed unless replaced. Removal of any windows not within a street-facing Façade is allowed if approved by the Village Planner. In the case of such removal, the case, sills, lintels and frame shall be removed, and the opening shall be closed so that it matches the adjacent wall unless it is a brick building in which case the opening can be filled in with brick that is the same color of the wall.

Remodeling shall not reduce, enlarge or change the shape of window openings or windows from the original or change the original fenestration, except in cases where non-compliant windows are being made compliant with the Pattern Book.

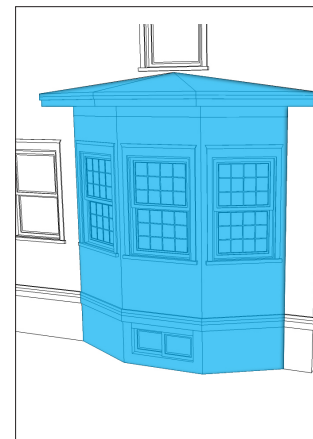
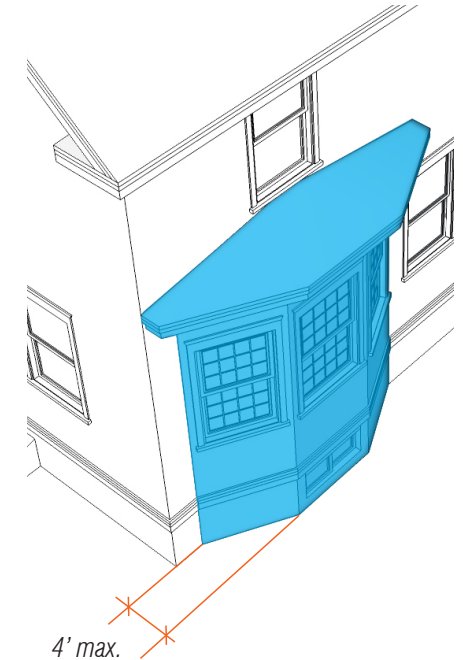

Allowed

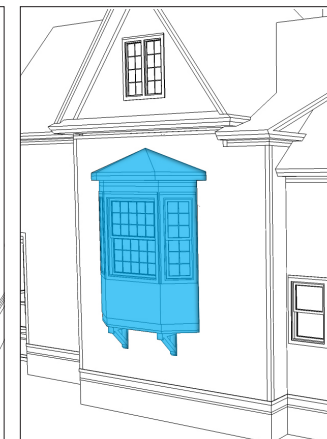

Allowed

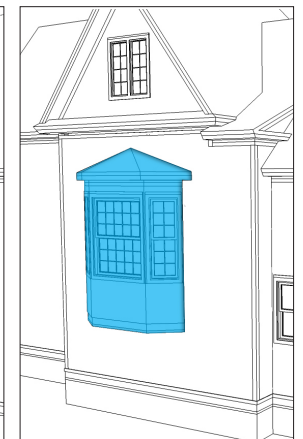

Not Allowed



# General Architectural Standards

## Doors

### Configuration

Door placement shall be consistent with the architectural style of the building in which they are used. Refer to the “Architectural Style Standards” section of the Pattern Book for additional information.

Paired front doors are discouraged on single-family houses.

### Types & Materials

The type(s) of door(s) used shall be consistent with the architectural style of the building in which they are used. Refer to the “Architectural Style Standards” section of the Pattern Book for additional information.

### Preferred Materials

Except for French doors and garage doors, doors shall be stained or painted wood constructed of planks or raised panels which express the construction technique (not flush with applied trim), and may have one or more windows.

### Acceptable Materials

Smooth fiberglass doors are permitted when trimmed to match windows.

### Prohibited Types

Doors and windows that operate as sliders are prohibited within Facades.

### Details

Door details shall be consistent with the architectural style of the building in which they are used. Refer to the “Architectural Style Standards” section of the Pattern Book for additional information. Depending on the style, doors may incorporate transoms, sidelights, or fanlights.

Doors shall have a lintel, face frame and drip mold.



# General Architectural Standards

## Roofs

### Pitched Roofs

Both hip and gable roofs are permitted but must be consistent with the architectural style of the building (see illustration at upper right).

Roof pitches shall typically be 8:12-14:12, as consistent with the architectural style of the building (see illustration at lower right).

Shed roofs are permitted at the rear or side, if ridge is attached to an exterior building wall (see illustrations at right).

Shed roofs may be 3:12-14:12 in pitch.

### Flat Roofs

Flat roofs are permitted, with a parapet, only on University Avenue and/or Highway 41A unless otherwise approved by the Village Planner.

Flat roofs, if allowed in the applicable Character District, are encouraged to be occupied and accessible from an interior room, in which case, they shall be edged by a railing.

Flat roofs shall be enclosed by parapets, of at least 42 inches high or such greater height as required to conceal mechanical equipment from view from any Frontage.

### Materials

Pitched roofs shall be asphalt shingle, standing seam aluminum, or other metal types in Galvalume finish is also acceptable.

Except for “green roofs”, flat roofs shall use white membrane/high albedo roofing materials.

Flashing shall be galvanized metal or copper.

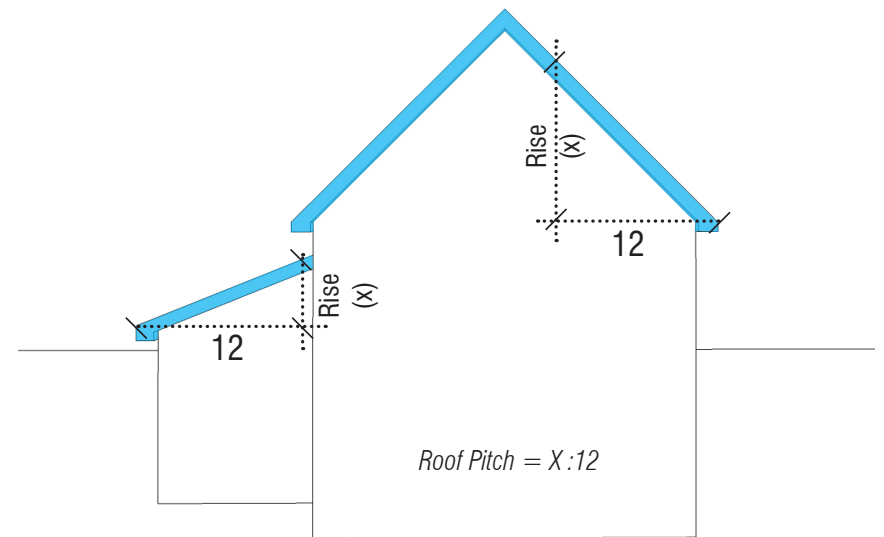
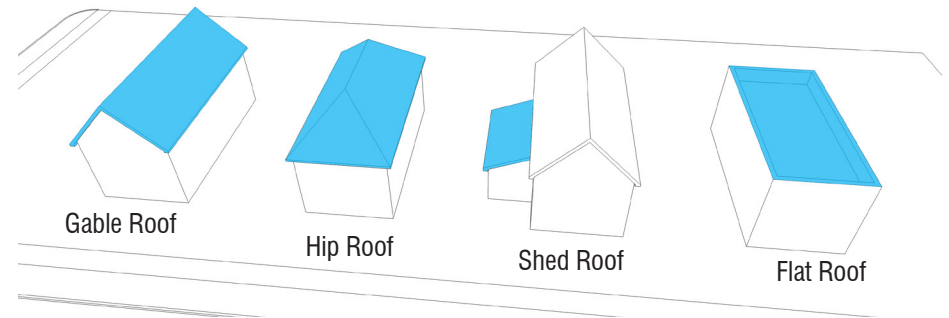



### Nested Gables

Overlapping or “nested” gables are not allowed, with the exception of historically appropriate nested gables on Craftsman or certain Victorian style houses, as approved by the Village Planner.

A nested or overlapping gable is a small gable inset inside a larger gable. The smaller gable may share the same roof plane on one side as the main roof plane or may be a separate distinct roof structure set slightly lower than the main roof (see illustrations at right).

The appropriate use of a nested gable is to roof entrances and attachments such as porches and stoops or bay windows or projections for entire rooms.

Nested/overlapping gables must serve an architectural function and may not be used in a purely decorative manner.

If a nested gable is deemed appropriate, it should project according to the depth of the porch, stoop or bay window.

For nested gables on a room bump-out, the depth should be a minimum of four feet to allow for functional, habitable space, not just for visual interest.

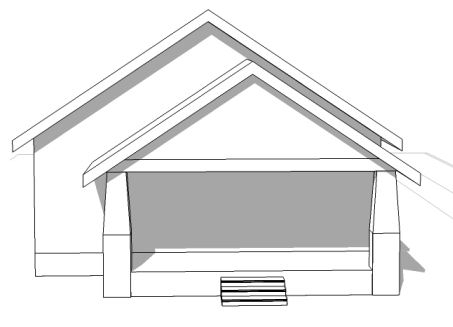

*Nested gable over porch, set slightly lower than the main roof.*

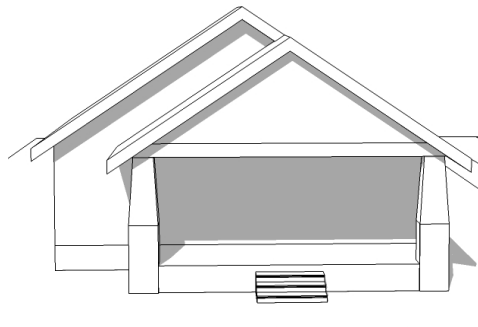

*Nested gable over porch, with porch roof sharing the same plane as the main roof on the right side.*



*Above, the appropriate use of a nested gable for the porch of a Craftsman building. The nested portion of the roof covers the entire porch and shares the same roof plane on one side as the main roof.*

*Below, the inappropriate use of a nested gable that is bumped out less than four feet, likely only to provide visual interest to the facade.*



# General Architectural Standards

## Roofs

### Eaves & Rafters

Eaves may be open or closed, as appropriate to the architectural style of the building. Eaves should be continuous, unless overhanging a balcony or a porch. Roof and eave overhangs shall also be consistent with the style of the building. Refer to the “Architectural Style Standards” section of the Pattern Book for more details.

Eave returns shall be traditionally detailed so that the horizontal cornice wraps the corner and meets the slope of the roof. An excellent guide to detailing a proper eave can be found in “Get Your House Right” by Marianne Cusato & Ben Pentreath (see “Resources” at the end of this Pattern Book). An example of an appropriate eave detail from this book is included below. “Pork chop” eaves, as shown in the images at center and lower right, are not permitted.

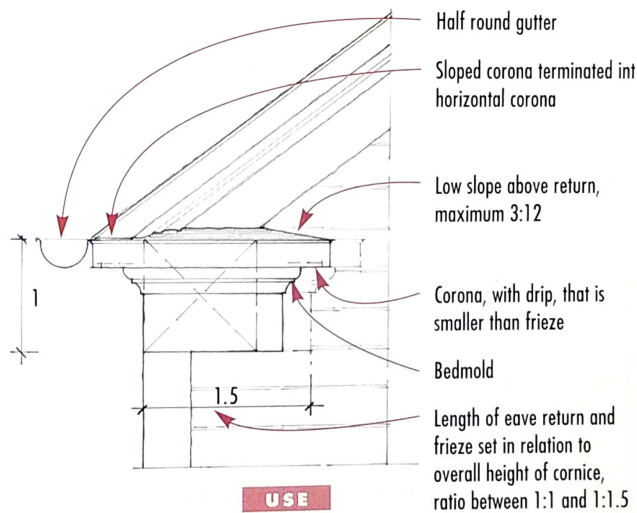

*YES: Proper eave return turns the corner and includes a small section of sloped roof with a low slope and materials that match the main roof materials. If done correctly, the sloped portion of the return should not be visible from the street.*

*NO: Intersection of roof at corner is improperly resolved*



*NO: “Pork chop” shaped eave returns are not architecturally appropriate*



*YES: A properly detailed eave return where the cornice wraps around the corner.*

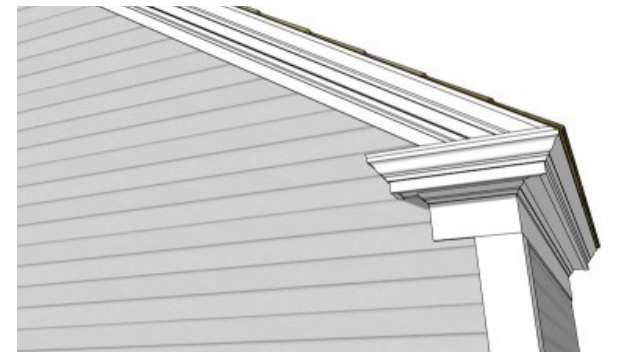



# General Architectural Standards

## Roofs

### Eaves & Rafters (continued)

The depth of eaves on Outbuildings shall match the eaves of the Principal Building on the lot if the latter are 18" or less deep, or shall be half the depth of the eaves of the Principal Building on the lot if the latter are more than 32" deep.

Eaves are allowed to encroach into Setbacks a maximum of 2', but may not extend into the public right-of-way.

Rafter tails shall not exceed 6" in height at their ends.



Above, a Craftsman house with a continuous, closed eave with a deep overhang.

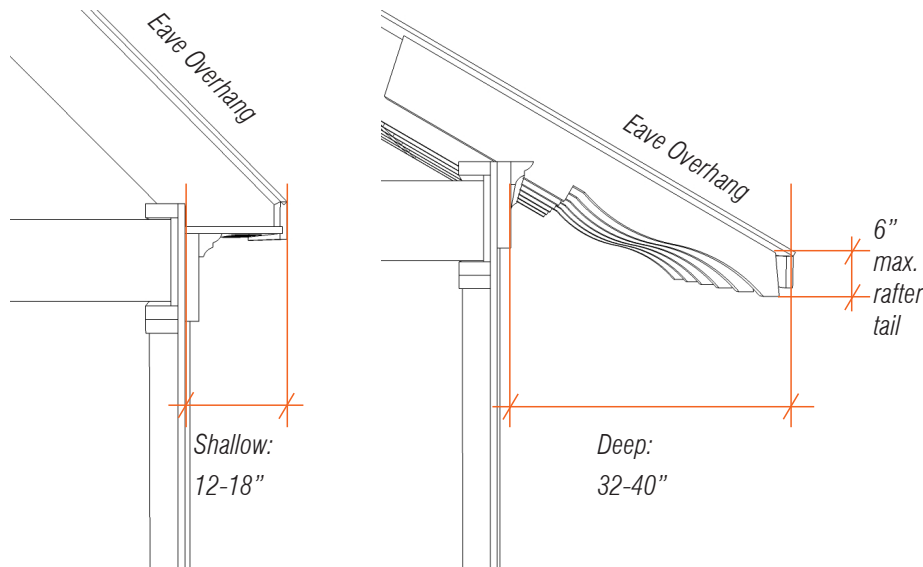

Below, a Folk Victorian house with a continuous eave with a shallow overhang.



# General Architectural Standards

## Roofs

### Dormers

Dormers should be comprised of one or more (grouped) windows in a single casing board. The dormer face should be no larger than the window(s) and casing. They should not have siding between the window and the edge of the dormer.

Dormers shall be roofed with a symmetrical gable, hip, or shed roof, and shall be at least three (3) feet from the side wall of the dormer to any outside building wall (see illustration at right).

Dormers shall have at least one window and be habitable.

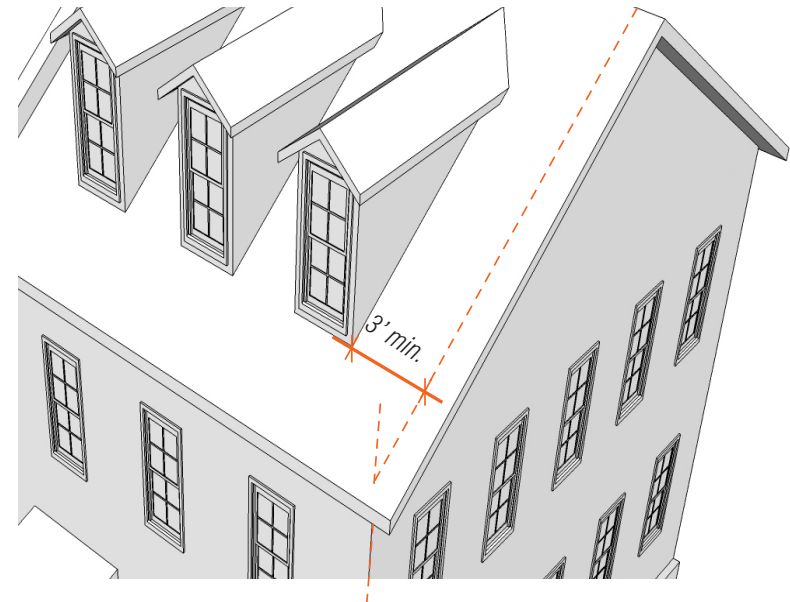



# General Architectural Standards

## Roofs

### Green Roofs & Rooftop Solar Panels

Any building may have a “green” roof, provided that such roof otherwise complies with the roof type and pitch standards of the applicable Character District (illustrations follow).

Solar shingles and panels are encouraged provided they are not visible from a Public Frontage.

### Maintenance & Repair

Deteriorated roof material shall be replaced with material which matches the original as closely as possible, or is of higher quality that adheres to the standards of this Pattern Book.

### Roof Vents & Penetrations

In the Village Center and Village Edge, roof penetrations other than chimneys shall be placed so as not to be visible from the public right-of-way and shall be black or match the color of the roof except those made of metal, which are allowed to be left natural.

Roof-mounted vents shall not be visible from any Frontage.



*Green Roof Example*

# Porches, Stoops, Decks & Balconies

## Configuration

The width of a Porch should be between 60% and 120% of the width of the associated Façade.

Porch openings between columns, posts, columns or arches shall be vertical in proportion (see illustration at right).

Porches shall be a minimum of 8' deep.

Stoops shall be 4' to 6' deep.

Porches are allowed to be enclosed with glass or screens.

Porch ceilings are allowed to be enclosed.

Decks shall be permitted only in rear yards and on rooftops. Decks are not permitted at the Frontage.

Decks shall not be visible from any Public Frontage or elevated more than 18" above the roof surface.

Balconies shall be visibly supported by brackets or beams and shall be at least 4' deep.

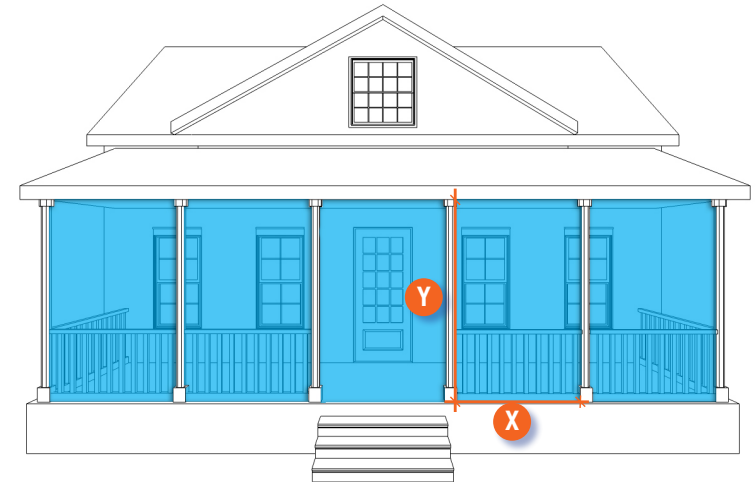

$$X < Y$$

(Vertically proportioned)





# Porches, Stoops, Decks & Balconies

## Materials

The area beneath a Porch shall be enclosed on all sides with an allowed wall material or an approved lattice.

Porch decking in the Front Yard shall be made of painted or opaque-stained wood, painted or unpainted brick, painted, unpainted, or stained brick or concrete panels, ceramic tile, or natural stone or stained concrete, if consistent with the architectural style of the building to which the porch is attached. All porches shall be faced on three sides with natural stone, painted or unpainted wood or painted or unpainted brick.

Stoops shall be finished in painted or opaque-stained natural wood, natural stone, integral color or painted stucco, natural stone, or painted or unpainted brick, if consistent with the architectural style of the building to which the stoop is attached.

Decks shall be made of natural, painted or opaque-stained wood, or in the case of roof tops, stained concrete, concrete pavers, bricks or brick pavers or ceramic tile.

Columns, posts and piers shall be painted or stained natural wood graded better than 2, painted PVC, painted or unpainted brick, or natural stone.

Railing balustrades shall be built of painted or opaque-stained wood or painted synthetic wood.

## Details

Porch and stoop details shall be consistent with the architectural style of the building in which they are used. Refer to the “Architectural Style Standards” section of the Pattern Book for additional information.

Railings shall have top and bottom rails centered on the balusters, boards or pickets (see illustration at right).



*NO - Porch is not enclosed and is unpainted*



*Yes - Porch is completely enclosed and is painted to match the house*

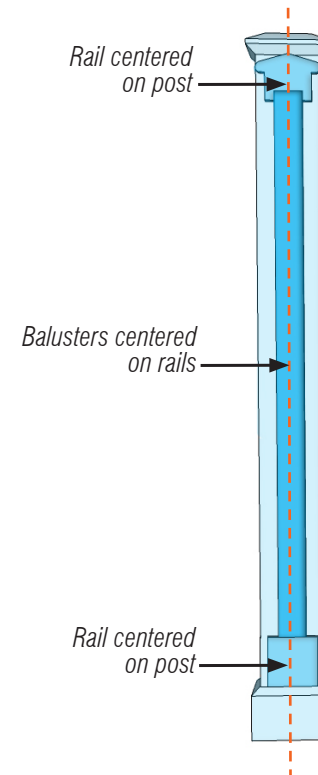

# Porches, Stoops, Decks & Balconies

The face of the porch column shall align with the face of the porch beam or entablature (see illustration at right). The column cap shall extend beyond the edge of the column and the face of the beam.

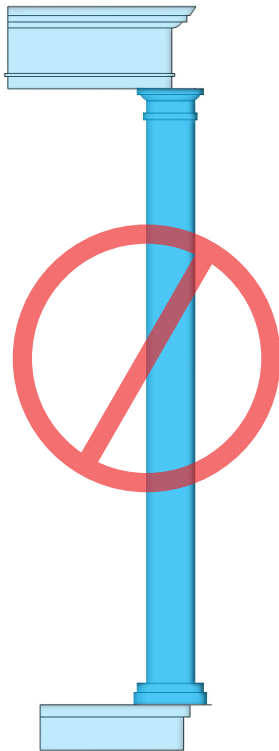

*NO - Column is set too far forward*

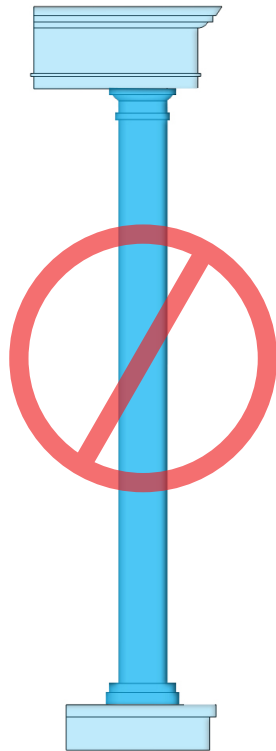

*NO - Column is set too far back*

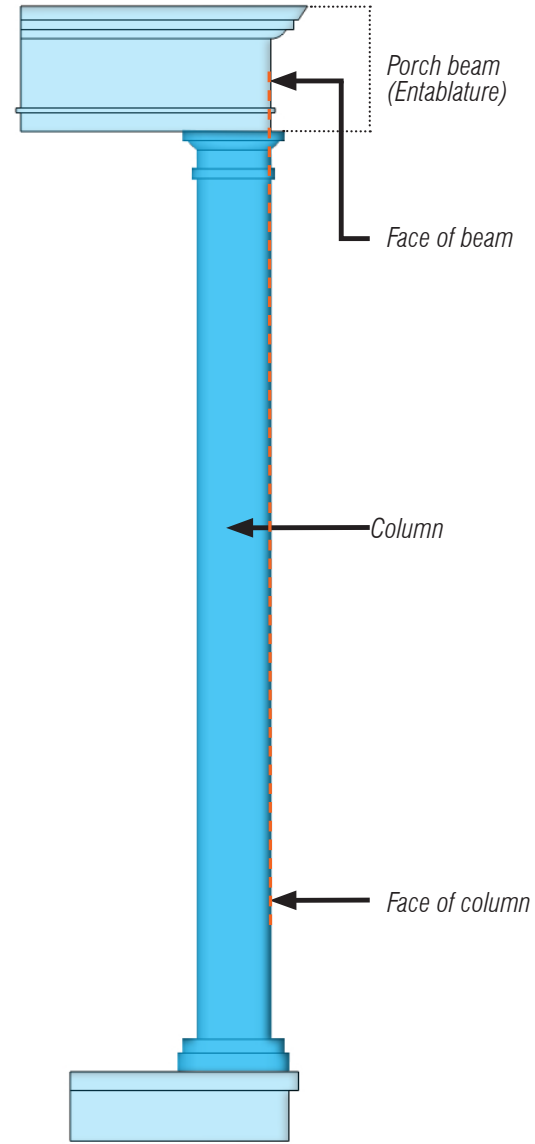

*YES - Column face is aligned with face of beam*

# General Architectural Standards

## Chimneys

### Configuration

Chimneys shall extend below finished ground as true masonry structures (see illustration at right).

### Materials

Chimneys and chimney enclosures, shall be constructed of masonry and finished with painted or natural brick, natural stone, or painted or integral color stucco.

Flues shall be tile or metal left to age naturally or painted black.

### Details

Each chimney shall have a projecting cap.

Chimneys shall be a minimum of 32" square in plan and shall be capped to conceal spark arresters.

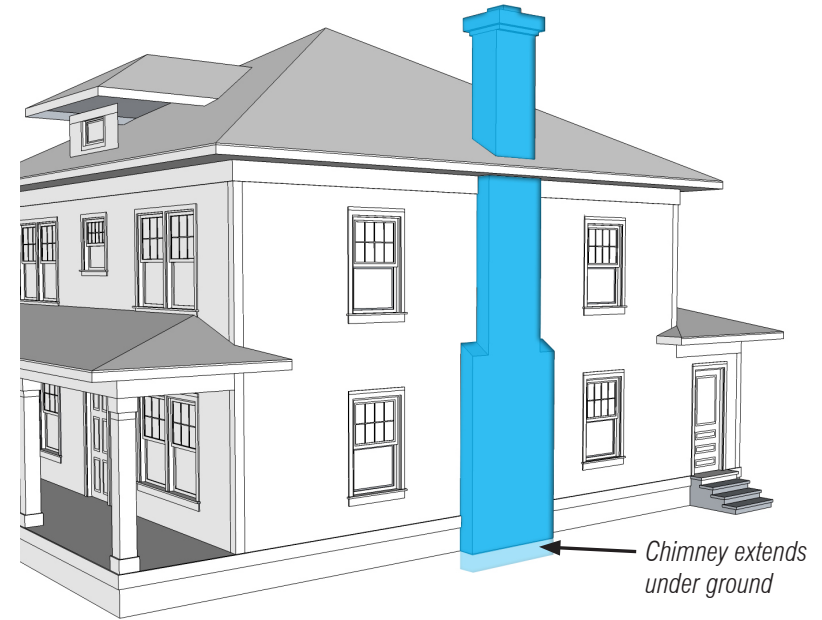



# Carriage Houses, Garages & Outbuildings

## Outbuildings

The term “Outbuilding” refers to garages, carriage houses, carports, sheds, or any other attached or detached building other than the Principal Building. A small detached structure such as a potting shed or gazebo (no larger than 10’ by 10’) may be permitted as a second outbuilding with the recommendation of the Village Planner and the approval of the Lease Committee. Please refer to page 10 for additional information about outbuildings.

Sewanee encourages the use of Outbuildings as Accessory Dwelling Units, subject to the applicable Franklin County zoning regulations.

Prefabricated sheds or carports are not permitted in the Village Center when visible from a thoroughfare. They are discouraged in all other Character Districts as most prefabricated sheds and carports will not meet the material and detail requirements of the Pattern Book. However, prefab sheds and carports may be considered based on sight lines from the street and neighboring houses.

## Placement

Refer to “Illustrated Concepts and Terms: Principal Building vs. Outbuilding” on page 7 and the “Lot Patterns” diagrams on pages 8-17 for Outbuilding location requirements. Street-loaded garages are encouraged to be side-loaded, especially in the Village Center and Village Edge.

## Materials

As discussed earlier in the Pattern Book, Outbuildings shall match the style, form, color, materials and details of the associated Principal Building.



## Details

As referenced in the “Roofs” section of the Pattern Book, the depth of eaves on Outbuildings shall match the eaves of the Principal Building on the lot if the latter are 18” or less deep, or shall be half the depth of the eaves of the Principal Building on the lot if the latter are more than 32” deep.

Garage doors must be single-width. Double-width garage doors are not permitted where visible from the street. Garage doors facing the street are encouraged to have windows and/or carriage-style doors.

If garages are side-loaded, they should have windows on the side facing the street.

One- and two-car garages or carports are permitted in all parts of Sewanee Village. Three-car garages or carports are not allowed in the Village Center, Village Edge or Cottage Court Character Areas. Three-car garages in the Village Neighborhood shall face the side or rear of the lot, or be located behind the house so that all three doors are not visible from the street.



# Carriage Houses, Garages & Outbuildings





# General Landscape Standards

## Residential Driveways

### Driveway Placement

The “Lot Patterns” section of the Pattern Book addresses the location of Outbuildings on each lot. Parking areas shall be in the Back Yard only. Driveways shall be used to connect Garages or Carriage Houses to the street using the shortest route possible.

Driveways shall be straight and perpendicular to the street or alley/lane, except when topography or existing vegetation prohibits such configuration. Circular or semi-circular driveways are not permitted. However, site-specific considerations will be given for driveway placement and design. In such cases, the location and trajectory of the garage shall be reviewed by the Village Planner and Lease Committee as part of the site plan review.

Driveway openings (where the driveway meets the street) shall be no more than 10 feet in width.

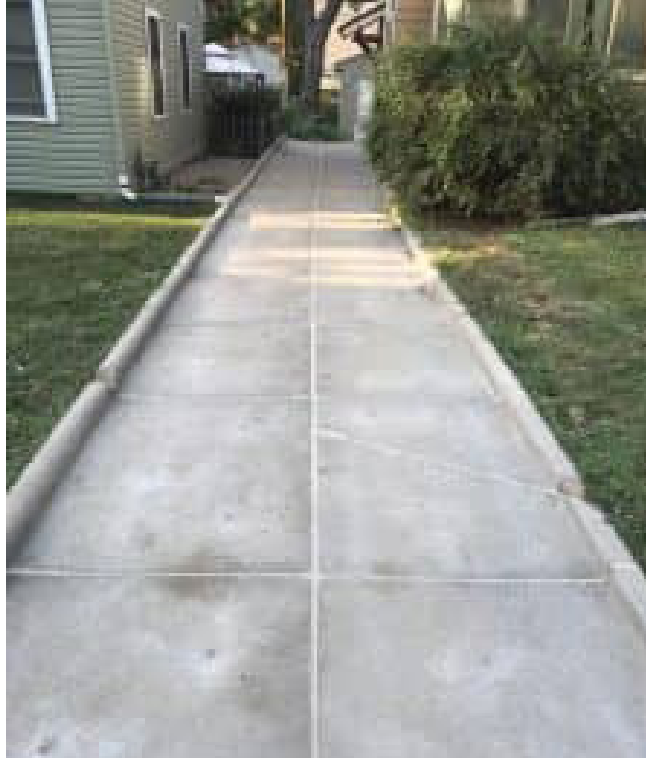

### Driveway Materials

Driveways shall be made of concrete (unstained), brick, stone pavers, gravel, or permeable pavers. In order to be consistent with the desired timeless and traditional character of the Sewanee Village, asphalt is not permitted. Gravel driveways shall have an appropriate edging to prevent washout. A grass strip or “ribbon” may run down the middle of the driveway; in fact, this is recommended to reduce impermeable surface areas.

Some of these permitted driveway materials are shown in the images at right.

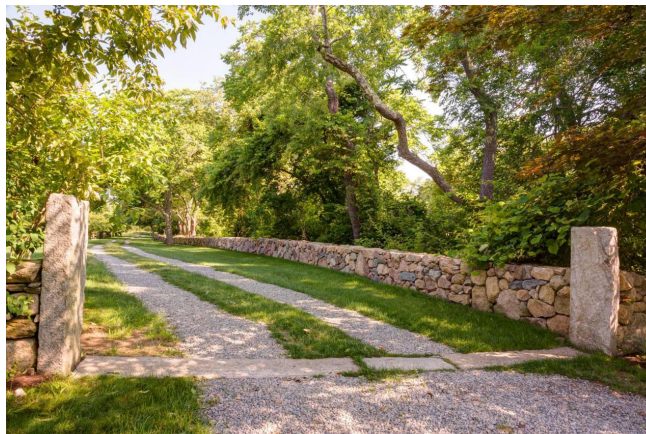



# General Landscape Standards

## Fences, Walls & Hedges

### General Standards

Fences and walls should be designed and detailed to be harmonious with the architectural design of the buildings with which they are associated.

Historically, fences in Sewanee have been made of wood, while walls are made of stone. Wood, stone, or a combination of the two are preferred materials for fences visible from the public right-of-way or any adjacent civic spaces. Hedges may be combined with fences, walls, piers or gates. Specific material requirements are provided below.

Fences and walls shall be categorized as Yard Fences or walls (those which provide definition to the boundaries of a leasehold) and Screening Fences or walls (those which provide opaque or semi-opaque screening of equipment, or provide privacy to the leaseholder from adjacent uses).

All fences, walls, piers and gates shall be well-maintained, in upright condition and free of missing or broken parts.

The height of a fence or wall shall be measured from the average undisturbed grade of the adjacent property at the property line.



*Stone Wall with Metal Gate*



*Split Rail Fence*



*Horizontal Rail Fence with Stone Piers*



# General Landscape Standards

## Fences, Walls & Hedges

### Location of Fences, Walls & Hedges

Fences and walls are permitted in the front, side, and rear yards.

Fences that are finished on both sides are preferable to single-sided designs.

In all cases, the “finished” side of a fence shall face the adjacent property, thoroughfare, path or passage.

Any fence proposed along a common property line must be coordinated with the adjacent lease. Reasonable efforts must be taken to accommodate the needs, desire, and requirements of each owner.

Fences or walls at frontages on neighboring leaseholds should be of different designs.

### Yard Fences or Walls

Fence/Wall height shall be 30 inches minimum, 48 inches maximum at frontages. Side yard fences and walls shall be 30 inches minimum, 72 inches maximum.

### Screening Fences or Walls

Screening from frontage, civic space, and adjacent property is required for parking, loading areas, service areas, drive-throughs, trash receptacles, HVAC and other equipment. Screening may be by building wall, hedge or fence.

Screening fences or walls, if required, may be 42 inches minimum, 72 inches maximum at frontages or adjacent to civic spaces. Other screening walls may be 5 to 6 feet tall. If hedges are provided for screening, they should be 5 to 6 feet tall at installation.

Fence/wall height shall be 30 inches minimum, 48 inches maximum at frontages. Side yard fences and walls shall be 30 inches minimum, 72 inches maximum.

The upper portion of a screening fence or wall may be designed to be semi-opaque, by incorporating a lattice or grid pattern above 4 feet in height.



*Stone Wall with Stone Piers*



*Natural Wood Fence and Gate*



*Hedge with Piers and Gate*



# General Landscape Standards

## Fences, Walls & Hedges

### Preferred Materials

Fences shall be made of natural wood, metal, or iron in all Character Districts. However, in the Village Edge and Village Neighborhood Character Districts, or in the rear of a leasehold in any District, fences may be made of black aluminum. Wood may be stained in a natural color or painted white. In the Village Center, Village Edge, and Cottage Court Districts, all Fences at Facades shall be picket-type. In the Village Neighborhood District, Fences at Facades may be picket-type or horizontal rail. Split-rail fences may be approved by the Village Planner for use in the Village Neighborhood District only. In all Districts, other fence types may be allowed at the side and rear yards.

Fences may be placed on top of low (12-18") walls or between stone piers.

Gates may be wood or metal and should be the same material as the fence unless otherwise approved by the Village Planner. Gates in walls shall be compatible with the wall with which it is associated.

Piers and posts shall be wood or natural stone.

Walls shall be made of natural stone.

Streetscreens shall be constructed of a material matching the Facade wall of the Principal Building on the lot.

### Prohibited Materials

Barbed wire fences are prohibited throughout the Sewanee Village.

Chain link fences are prohibited in the Village Center and Village Edge Districts in any areas visible from the public right-of-way. Chain link fences may be used in the Village Neighborhood District at the rear and sides only.



*Painted Picket Fence*



*Painted Wood Horizontal Rail Fence with Posts*



*Black Aluminum Fencing*



# Sewanee Village +

Appropriate Architectural Styles





# Appropriate Architectural Styles

## Introduction

The process of architectural visioning for the Sewanee Village began in 2015 with the Sewanee Village Implementation Plan. The renderings created during this process introduced imagery of a compact rural village with a range of historically and regionally appropriate styles, from three-story brick shopfronts in the downtown core to metal-roofed folk cottages in the surrounding residential neighborhoods. Though conversations with residents and business owners in and around the Village, we learned which of the buildings in Sewanee are most-loved and which are least-liked. A more detailed assessment of the existing residential and commercial buildings in and around Sewanee led to a list of predominant architectural styles considered most appropriate for new buildings in the Village. The next few pages contain images collected in Sewanee (“Local Precedent”), as well as several other highly-regarded historical districts in the greater Tennessee region, such as the Monteagle Sunday School Assembly, downtown Franklin, Leiper’s Fork and downtown Winchester (“Regional Precedent”).

An additional section, “National Precedent” includes images from our planning and architecture library of buildings across the nation that exemplify the vision of a picturesque rural village that stands on its own, unique and independent of the neighboring University of the South campus.

The images contained in this “Precedent” section of the Pattern Book are not intended to provide exact examples of buildings that should or will be built in downtown Sewanee. Rather, they give a broad view of the architectural character intended for the completed Village, and help inform the specific style standards that follow.





# Architectural Style Standards

## Local Precedent - Residential





# Regional Precedent - Residential





# Architectural Style Standards National Precedent - Residential





# Village Architectural Styles - Summary

The following four architectural styles have been identified as the most appropriate for new buildings in downtown Sewanee. While each of the four styles are commonly recognized in American architectural history, this Pattern Book provides guidelines and standards for a version of each that is calibrated to the character of Sewanee and the surrounding area, based on careful study of regional precedent.

## Folk

**Categorized by:**

- Simple, rectangular massing;
- Typically gabled roof;
- Simple, balanced arrangement of windows and doors;
- Lack of detail & ornamentation;
- Simple materials, primarily wood siding and metal roofing.



## Folk Victorian

**Characterized by:**

- Simple, rectangular massing;
- Typically gabled roof;
- Simple, balanced arrangement of windows and doors;
- Victorian detailing, typically to the porch cornice and gables;
- Simple materials, primarily wood siding, metal roofing, and wooden ornamentation.



## Craftsman

**Characterized by:**

- Simple square or rectangular massing;
- Low-pitched gabled roof with deep overhangs;
- Balanced arrangement of windows and doors;
- Wooden craftsman detailing, including exposed rafters and beam ends, decorative brackets;
- Natural materials, including wood siding and shingle or metal roof.



## Colonial Revival

**Characterized by:**

- Simple, rectangular massing;
- Hipped or gabled roof;
- Typically symmetrical arrangement of windows and doors;
- Classical detailing, including columns, pediments, and elaborate door surrounds;
- Simple materials, primarily wood siding and shingle or metal roof.



# Village Architectural Styles - Summary

The following two architectural styles have been identified as they are an important part of the architectural fabric of Sewanee and require dedicated oversight from the Sewanee Village Planner.

## Ranch

### Characterized by:

- Single level
- Simple, rectangular massing with the west side of the building facing the street;
- Long, low roofline;
- Typically asymmetrical arrangement of doors and large windows;
- Simple materials, primarily masonry stone or brick;
- Attached garage.



Ranch style is not allowed for new construction, however the style is described as there are several instances of this style within the Village District.

Should the leaseholder choose to renovate or make visible alterations to a Ranch style house, the leaseholder will be required to work closely with the Village Planner to ensure the design of those renovations or alterations have accurate and appropriate details, proportions and materials based on project goals and style desired.

## Sewanee Eclectic

### Characterized by:

- Varied roofline;
- Irregular massing and form, as reflected by the combination of architectural styles;
- Combination of materials, including stone, brick, wood siding;
- Varied arrangement of doors and large windows depending on the combination of architectural styles;
- Incorporation of projecting bays, wings, or pavilions to create visual interest;
- Ornamentation.





# Architectural Style Standards

## Folk

### General Description

Many historic homes in rural Tennessee can be classified as the Folk style, and there are a number of excellent examples in Sewanee and the surrounding region. Folk architecture is categorized by simple massing and detail, lack of ornamentation, and the predominant use of wood siding and metal roofing. This style is most appropriate for single-family homes and cottages.

### Form & Massing

There are three primary variations of the Folk style found in the Sewanee area, each of which feature a simple gable roof with a low to moderate pitch, and square or rectangular primary massing. Examples can be found on the following pages.

1. Side Gable
2. Front Gable
3. Gable & Wing





# Architectural Style Standards

## Folk

### Form & Massing: Side Gable Variations

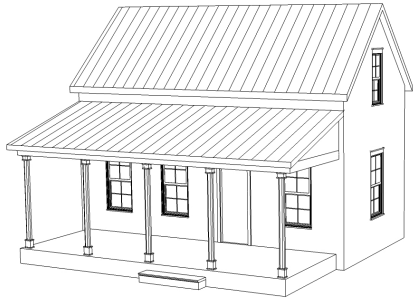

One- to one-and-a-half story massing, hall-and-parlor plan (two rooms wide, one room deep). Full-width porch with hipped or shed roof.

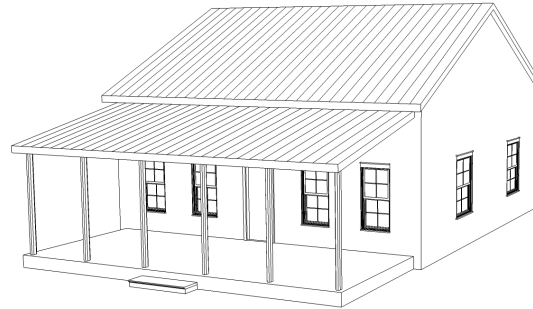

One- to one-and-a-half story massing, massed plan (two rooms wide, two rooms deep). Full-width porch with hipped or shed roof.

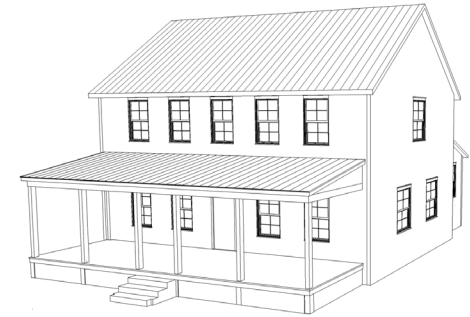

Two story massing, one or two rooms deep, one room wide. May have a single-story addition with a shed roof on the rear. Full- or partial- width porch with hipped or shed roof





### Form & Massing: Front Gable Variations

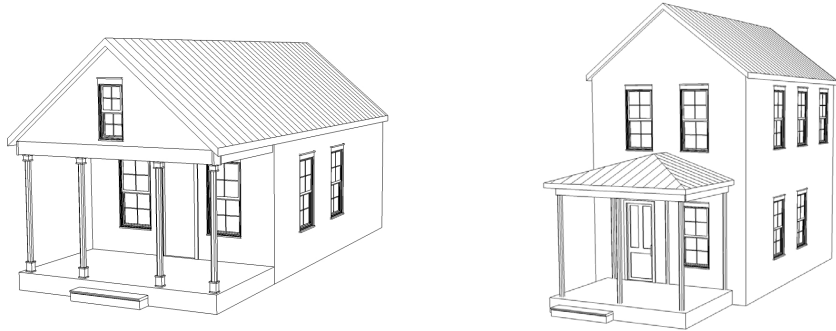

One- or two-story massing, one room wide. Ideal for narrow lots and cottage courts. Full- or partial-width porch with hipped or shed roof.

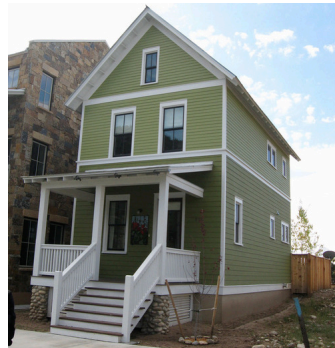

### Form & Massing: Gable & Wing Variations

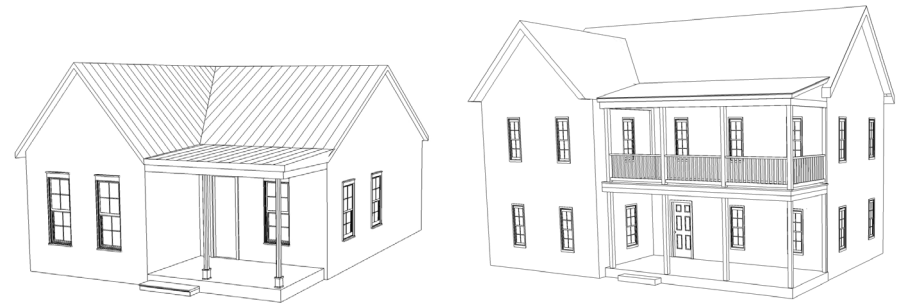

One- or two-story massing with a wing at a right angle to the gabled front, often set back the depth of the porch. Full- or partial-width porch with shed or hipped roof.





# Architectural Style Standards

## Folk

### Porches:

The porch typically runs the full width, or about two-thirds the width of the primary massing, and has a hipped or shed roof. Porches may wrap around.

The finished floor level of Folk homes may range from 6" to 30", typically, though a 6" to 12" range is most common.

Folk houses with a low finished floor level (6"-12") are not required to have a porch railing on the ground level. If porch railings are provided, they should be simple and minimally detailed.

### Doors & Windows:

Doors and windows are simple, with minimal detailing. The heads of doors and windows should align.

Windows are most often 1-over-1 single double-hung, which may be smaller on the second floor. Paired windows are not typical, but may be used if appropriately scaled and detailed.

Shutters are less common with this style, but may be used if appropriately sized and detailed.

Doors are typically solid, or half-glass.

*Balanced elevation with windows and doors symmetrical and aligned.*

*Simple full-width porch with hipped roof, square columns and no railings, since finished floor is raised only a few inches.*



*Single double-hung windows on first floor, smaller fixed square windows on second floor.*



# Architectural Style Standards

## Folk

### Details:

Slight eave overhang with minimal detailing. Simply detailed porches with square wooden columns and simple rail details, though railings are not required. Chimneys are common, and may be central or on the gable end.

### Colors & Materials:

Primary materials should be horizontal wood siding and metal standing-seam roof. Vertical board and batten walls and/or asphalt shingle roofs may be allowed with special approval by the Village planner. Brick is appropriate only for chimneys and foundations.

Exterior colors shall be historically accurate and may include non-garish shades of yellow, blue, brown, red, green, or gray. Brighter shades may be approved by the Village Planner.

Folk houses should use no more than three exterior paint colors - one for the primary massing, one for the trim, and a third for the door or as a secondary trim color. All three colors must be complementary.



*Roof has a slight eave overhang with minimal detailing.*

*Partial-glass door painted in an accent color.*

*Simple color selections include light colored walls and roof, with white trim.*

*Simple square columns and railings on raised porch.*





# Architectural Style Standards

## Folk Victorian

### General Description

A more decorative version of the Folk style described on the previous pages, Folk Victorian homes are characterized by their simple massing and materials with the addition of Victorian detailing, typically to the porch, cornice and gables. This style is common across the country, with numerous examples in Sewanee, and particularly in the nearby Monteagle Sunday School Assembly. This style is most appropriate for single-family homes and cottages, but Victorian forms and details may also be used for small commercial buildings.

### Form & Massing

There are four primary variations of the Folk style found in the Sewanee area, including the three previously described in the Folk section. Those three feature a simple gable roof, while the fourth incorporates a pyramidal or hipped roof. Roof pitch may vary between 8:12 and 10:12. All have square or rectangular primary massing. Examples can be found on the following pages.

1. Side Gable
2. Front Gable
3. Gable & Wing
4. Pyramidal & Hipped

Houses with more elaborate massing and detail may be more accurately described as Queen Anne Victorian, which may also be appropriate to Sewanee if used in moderation.





# Architectural Style Standards

## Folk Victorian

### Form & Massing: Side Gable Variations

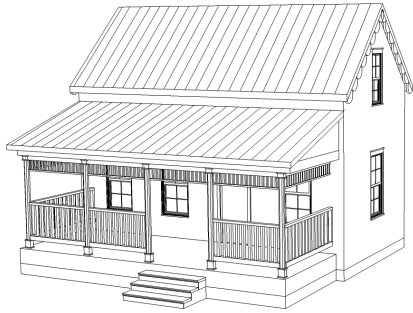

One- to one-and-a-half story massing, hall-and-parlor plan (two rooms wide, one room deep). Full- or partial-width porch with hipped or shed roof. There may be a cross gable over the porch as well.

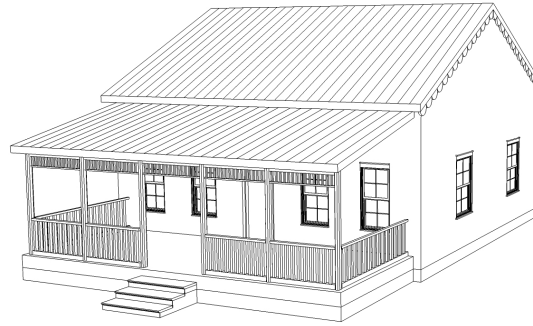

One- to one-and-a-half story massing, massed plan (two rooms wide, two rooms deep). Full- or partial-width porch with hipped or shed roof.

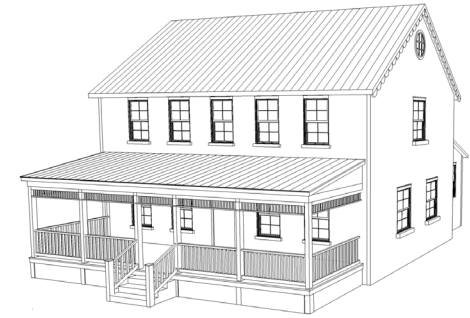

Two story massing, one or two rooms deep, one room wide. May have a single-story addition with a shed roof on the rear. Full- or partial-width one- or two-story porch with hipped or shed roof.





# Architectural Style Standards

## Folk Victorian

### Form & Massing: Front Gable Variations

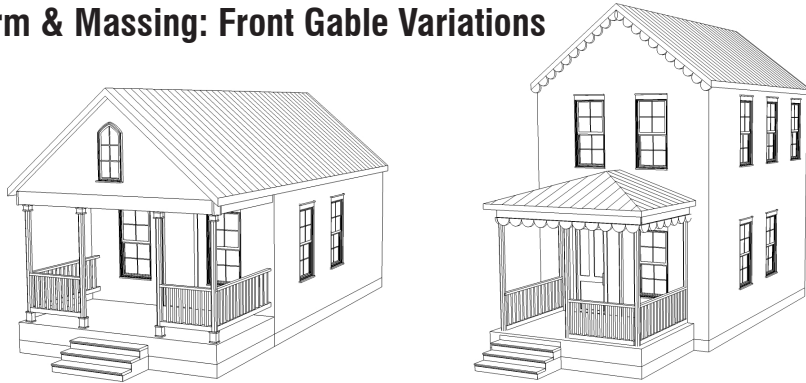

One- or two-story massing, one room wide. Ideal for narrow lots and cottage courts. Full-width porch may be incorporated under the main roof in one story variations, or may be an addition with a shed or hipped roof on two-story variations.



### Form & Massing: Gable & Wing Variations

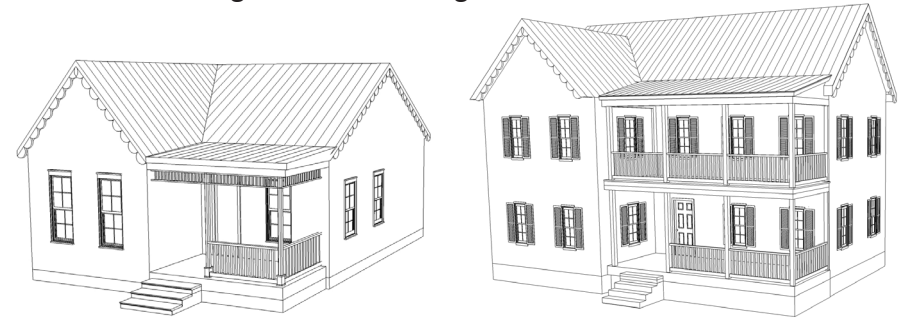

One- or two-story massing with a wing at a right angle to the gabled front, often set back the depth of the porch, though the porch may extend beyond the front gable in some cases. Full- or partial-width one- or two-story porch with hipped or shed roof.

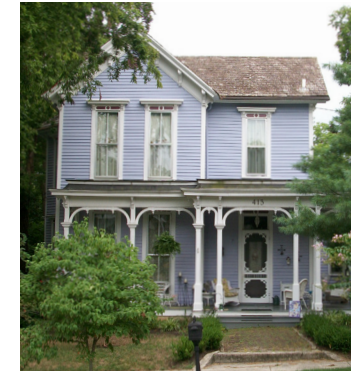



# Architectural Style Standards

## Folk Victorian

### Form & Massing: Pyramidal & Hipped Roof Variations



One- or two-story massing, with a hipped or pyramidal roof on the primary massing. May incorporate a gabled roof over secondary massing or the porch. Full- or partial-width one- or two-story porch with hipped, gable or shed roof.



Intentionally blank

# Architectural Style Standards

## Folk Victorian

### **Porches:**

The porch typically runs the full width, or about two-thirds the width of the primary massing, and most often has a shed or hipped roof. Porches may wrap around where appropriate, and two story porches are common.

The finished floor level of Folk Victorian homes may range from 6" to 36", though an 18" to 30" range is most common for houses on a raised foundation.

Folk Victorian houses with a low finished floor level (6"-12") are not required to have a porch railing on the ground level.

### **Doors & Windows:**

Door and window composition is typically symmetrical and balanced, with the same type of windows throughout. The heads of doors and windows should align. Both doors and windows may be simple, as in the Folk style, or may have more elaborate details such as sills, lintels, transoms, or sidelights.

Windows are most often tall, vertically proportioned single double-hung, typically with a 2-over-2 or 4-over-4 muntins pattern. Second floor windows may be smaller than those on the first floor. Decorative vents or windows may be used in gables. Paired windows are not typical, but may be used if appropriately scaled and detailed. Windows may have rounded or Gothic arched tops.

Shutters are more common in Folk Victorian styles than in Folk, but must be appropriate sized and detailed if used.

Bay windows and dormers are common and must be detailed appropriately.

Doors are typically solid, or half-glass. Decorative screen doors are appropriate, and should match the trim of the house.

*Decorative window with Gothic arch.*

*Partial-width front porch with hipped roof beneath cross gable.*



*Balanced elevation with windows and doors aligned horizontally and vertically.*

*Full-width porch with shed roof, square columns, and decorative brackets and arch detail.*

*Tall, single double-hung windows with 2-over-2 muntins pattern and decorative header detail.*





# Architectural Style Standards

## Folk Victorian

### Details:

Ornamentation on Folk Victorian homes typically comes in the form of decorative wood trim and millwork. The style has a slight to moderate eave overhang (8 to 16 inches) with minimal detailing. Eaves may be open or closed, and may incorporate brackets on gable ends and/or decorative trim board. An oversized, decorative board may be applied to the gable end of raking eaves.

The most common location for Victorian detailing is on the porch, which may include a square or round columns, and decorative spindlework. Chimneys are common, and may be central or on the gable end.

### Colors & Materials:

Primary materials should be horizontal or vertical board and batten wood siding and metal standing-seam roof. Decorative shingles may be used, particularly on gable ends. Metal roofs are strongly encouraged. Brick is appropriate only for chimneys and foundations.

Exterior colors shall be historically accurate and may include white, gray, tan, or pastel shades of yellow, blue, red or green. Brighter shades may be approved by the Village Planner and may include historically accurate pinks, purples, turquoises, and oranges. Trim should be white (white trim is appropriate on white houses), a slightly darker shade of the main body color, or a complementary color in a shade darker than the main body color.

Folk Victorian houses should use no more than three exterior paint colors - one for the primary massing, one for the trim, and a third for the door or as a secondary trim color. All three colors must be complementary.

*Brick chimney, centrally located.*

*Decorative gable vent.*

*Two-story porch with decorative braces, trim, and balustrade.*

*Traditional light yellow house with white trim.*



*Simple shed-roofed porch with decorative scallop trim and two-color posts.*

*Traditional light green house with dark green as the primary trim color and red as a secondary trim color.*



# Architectural Style Standards

## Craftsman

### General Description

A popular style throughout the country, including middle and east Tennessee, the Craftsman style is a product of the Arts and Crafts movement in the early 1900s. While there are many authentic examples of the Craftsman style in the Sewanee area, it is also common to see Craftsman details applied to small vernacular cottages, often referred to as “bungalows.” This style is most appropriate for single-family homes and cottages, duplexes and apartment houses.

When it comes to Craftsman houses, it is important to get the proportions and details right in order to remain true to the style. As with the Victorian style, there are a variety of detail options, with many opportunities for customization.

### Form & Massing

There are three primary variations of the Craftsman style found in the Sewanee area, each featuring a low- to moderately-pitched (4:12 to 6:12) roof, deep roof overhangs, an emphasis on horizontal lines and a one- to two-story square or rectangular primary massing. Examples can be found on the following pages.

1. Side Gable
2. Front Gable
3. Cross Gable
4. Pyramidal/Hipped Roof

Nested gables are common in Craftsman houses, but must be appropriately detailed (see Nested Gables section under “Roofs”).

In addition to the primary massing, side porches, sleeping porches, pergolas and porte cocheres are common.





# Architectural Style Standards

## Craftsman

### Form & Massing: Side Gable Variations

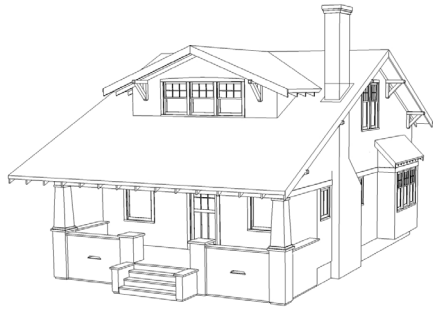

Typically one-and-a-half story massing, with the porch roof an extension of the main roof or slightly less pitched. Often has a large gabled or shed dormer. Typically have a full-width porch contained under the roof of the primary massing.



### Form & Massing: Front Gable Variations

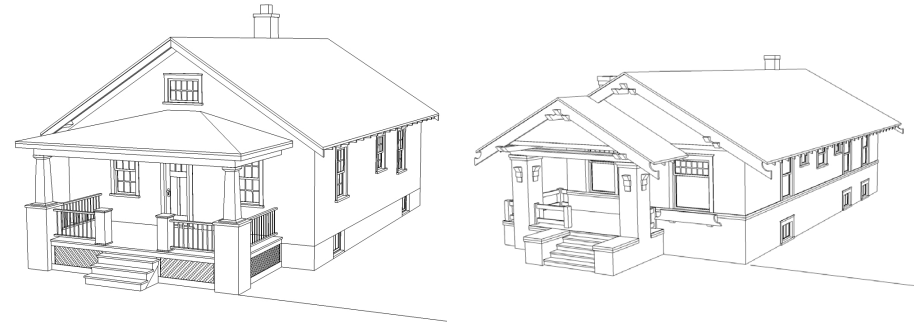

One- to two-story massing. Porch may be under a gable nested slightly lower than the gable of the main roof or an extension of one side of it.





**Form & Massing: Cross Gable Variations**



One- or two-story side-gabled massing with the porch roof serving as the intersecting, front facing gable.



**Form & Massing: Pyramidal/Hipped Roof Variations**



One- or two-story massing with a pyramidal or hipped roof, often with a central dormer. Porch may be shed or hipped and typically runs the width of the house. Porch may wrap around or extend to create a porte cochere.





# Architectural Style Standards

## Craftsman

### Porches:

Porches are typically single-story, wide and deep, with an emphasis on horizontal lines and large columns. The roof of the single-story porch depends on the roof and configuration of the primary massing, but typically has a low slope (3:12-4:12). Refer to the previous pages for details. Porches may wrap around or may incorporate pergolas, porte cocheres or carports.

Porches are typically supported on tapered round or square columns which may run all the way to the ground or may sit on massive piers or half walls. Non-tapered square wooden columns are also appropriate. Some variations may have paired columns instead of a single, large column. Porches should have the same rafter and eave details as the primary massing.

The finished floor level of Craftsman homes typically ranges from 18" to 30" for houses on a raised foundation.

### Characteristic Details:

The Craftsman style is easily identified by its characteristic porch and roof details. Deep, open eave overhangs of 18-30" expose rafter tails, and beam ends may project from gable ends. In addition, the cornice may have large knee-style brackets.

Large, prominent stone or brick chimneys are also common, and may be flanked by small high windows on either side.



*May have paired columns instead of single, large columns.*

*Simple, rectangular primary massing with full-width porch.*

*Large knee-style brackets under eaves.*



*Both have deep porches with large, tapered wooden columns set on brick piers.*

*Low-pitched roof with deep overhangs.*



*Large knee-style brackets under eaves.*

# Architectural Style Standards

## Craftsman

### Doors & Windows:

Windows are typically 3-over-1, 4-over-1, 6-over-1, or 9-over-1, vertically proportioned and double-hung, though casement windows are also common. Windows may be single, paired or grouped. High, square windows can be placed over stairs, bathrooms, and on either side of chimneys.

Doors are typically solid stained or painted wood or partial glass, and main entry doors may incorporate transoms and sidelights. Shutters are uncommon and therefore discouraged.

Decorative vents or windows may be used in gables.

Bay windows are common and must be detailed appropriately.

Dormers are common, particularly large, centered dormers, and may be gabled, hipped, or a single, wide shed dormer with grouped windows.

### Colors & Materials:

The Craftsman style emphasizes a mix of natural materials such as wood and stone. Exterior materials may include wood siding, wood shingles or shakes, vertical board-and-batten siding, and natural stone. Roofs are historically shingled, though metal roofs are encouraged in Sewanee. Brick is appropriate only for chimneys, porches, and foundations, and should not be used as the primary wall material.

Earth tones such as browns and greens, and light colors such as yellow, tan, and gray are the most appropriate to this style. However, local examples of Craftsman homes include reds, pinks and blues. White or light-colored trim should be used on darker colored houses, while dark trim may be more appropriate on light colored houses. In either situation, the colors should be complementary. Doors may be painted in a third, complementary accent color.





# Architectural Style Standards

## Colonial Revival

### General Description

Colonial Revival was the predominant style for houses between the 1880s and 1940s. The style combines simplified elements of Federal and Georgian architecture. While uncommon in more rural parts of the region, there are a number of excellent examples of Colonial Revival homes in the neighborhoods immediately surrounding the University of the South. This style is most appropriate for larger homes, rowhouses and apartment houses.

The common characteristics of Colonial Revival buildings are well-balanced, symmetrical facades with a main entrance that is typically centered and elaborated with transoms, sidelights, columns and/or pediments. Homes may have a pedimented stoop, a partial-width porch or a full-width porch.

### Form & Massing

In general, there are two primary variations on massing and roof form for Colonial Revival homes, each with sub-types based on their entry features. Houses are typically one- to two-story simple rectangular volumes with a moderately sloped (6:12 to 10:12) roof. Examples can be found on the following page:

1. Side Gable
2. Front Gable
3. Hipped Roof

In addition to the primary massing, side wings and porte cocheres are common.





# Architectural Style Standards

## Colonial Revival

### Form & Massing: Side Gable Variations

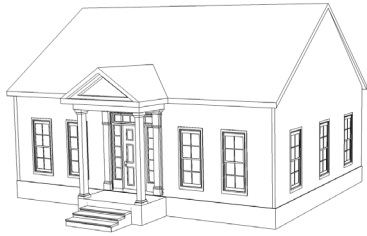

One- to one-and-a-half story simple rectangular massing. Typically incorporates a partial-width porch or stoop with pediment.

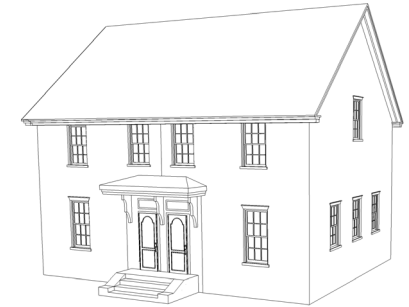
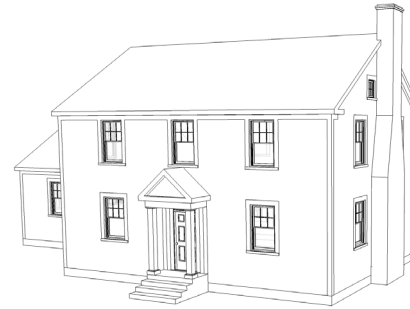

Two story simple rectangular massing, often with single-story wings on the sides. May have a one- or two-story porch with hipped or shed roof, a pedimented stoop, or a full-height pedimented entry.





# Architectural Style Standards

## Colonial Revival

### Form & Massing: Front Gable Variations



Two story simple rectangular massing, typically longer than it is wide. Ideal for narrow lots and cottage courts. May have a one- or two-story porch with a hipped or shed roof or pediment.



### Form & Massing: Hipped Roof Variations



One to three story massing with hipped roof. May have a one- or two-story porch with hipped or shed roof, a pedimented stoop, or a full-height pedimented entry.



# Architectural Style Standards

## Colonial Revival

### Porches:

Porches and pedimented stoops are equally common, depending on the style of influence. Refer to the previous pages for examples and details.

Stoops are typically covered with a gable roof and pediment.

Porches may be one-story or two. Single story porches have a hip or shed roof, while two-story porches are typically uncovered on the upper porch. Porch eave details are similar to those of the main building.

Porch and stoop roofs are supported by columns, either in one of the classical orders, or simple round or square columns. Narrow columns may be paired.

### Characteristic Details:

A boxed cornice with a 9" to 18" overhang is typical, and may be detailed with dentils, moldings or modillions.

Roofs may have a balustrade.

Columns at the main entry may be any of the classical orders, or simplified square or round columns. Corner pilasters are common.

Chimneys are common but should be placed on gable ends only.

*Example incorporating a chimney, bay window, and two-story porch with portico.*



*Two-story porch with classic round columns and upper level balustrade.*

*Main entry door incorporates a transom and sidelights.*



*Two story porch with pedimented roof and fanlight in pediment.*

*Balanced facade with windows and doors on each floor aligned.*

*Main entry door incorporates a rounded transom and sidelights.*



# Architectural Style Standards

## Colonial Revival

### Doors & Windows:

Window arrangements are typically symmetrical and repetitive, with equal space between windows and doors across the facade. The heads of doors and windows should align. Windows are typically vertically proportioned and double-hung, and may be single, paired or grouped. Double-hung windows are typically 6-over-1, 6-over-6, 8-over-1, 8-over-8, 9-over-1, 9-over-9, 12-over-1, or 12-over-12. Second story windows should be the same width as first story windows, though they may be shorter, as long as panes are of similar proportions.

Doors are typically centered on the primary massing, and may be solid wood, wood with partial glazing, or fully glazed. Six- and eight-panel doors are the most common. Main entry doors may incorporate sidelights and transoms or fanlights. Sidelights may be used without a transom or fanlight as well. Palladian windows are permitted on the second floor above the entry.

Shutters are typical and must be appropriately sized and detailed.

Bay windows and dormers are common and must be detailed appropriately.

### Colors & Materials:

While brick is a traditional material for American houses in the Colonial Revival style, it is less appropriate, and less used, in the Sewanee area. Horizontal wood siding is the preferred material, though brick may be used for foundations, porches, stoops and chimneys. Roofs are typically asphalt shingles, though metal roofs are encouraged.

White is the most traditional color for Colonial Revival homes in Sewanee, though other historically appropriate light colors including shades of yellow, tan and gray are permitted. Trim is typically white, and shutters are most often black or dark green. All colors should be complementary. Doors may incorporate an accent color, such as deep red.

*6-over-6 double-hung windows with appropriately sized shutters and trim.*



*Stoop with pedimented roof.*

*Light gray house with white trim, black shutters and accent door painted deep red.*

*Partial-glass main entry door with fanlight and sidelights.*



# Architectural Style Standards

## Ranch

Ranch style is not allowed for new construction, however there are several instances of this style within the Village District.

Should the leaseholder choose to renovate or make visible alterations to a Ranch style house, the leaseholder will be required to work closely with the Village Planner to ensure the design of those renovations or alterations have accurate and appropriate details, proportions and materials based on project goals and style desired.





# Architectural Style Standards

## Sewanee Eclectic

There are a number of other architectural styles represented in Sewanee and the surrounding region, and it is not the intention of this Pattern Book to stifle creativity and create an overly homogeneous Village. Should a leaseholder choose to build a house in a historically accurate and regionally appropriate style other Folk, Folk Victorian, Craftsman or Colonial Revival, he or she should consult with the Village Planner to determine whether a different style may be permitted on the given leasehold. He or she will then be required to work closely with the Village Planner to design the house using accurate and appropriate details, proportions and materials. The images at right show an existing Sewanee house in the Dutch Colonial Revival style, a very unique medieval-inspired house, and several cabin-style homes that are generally more elaborate in form than the Folk style.

Another unique feature of the existing architecture in Sewanee is the occasional pairing of two different architectural styles, such as the house with the red porch that incorporates both Craftsman and Victorian details; and Fulford Hall, which can be described as both Victorian and Colonial Revival. Mixing characteristics of two different styles requires special approval of the Village Planner.



Fulford Hall





# Sewanee Village + Mixed-Use & Commercial Standards





# Introduction

The next section of this Patten Book sets additional standards that apply to Commercial Buildings in Sewanee. The following standards are applicable in the Village Center and Village Edge Districts.

Commercial Buildings in Sewanee follow the same architectural style standards as residential buildings throughout Sewanee in addition to the standards on the following pages. The next several pages lay out the architectural style standards that specifically apply to Commercial Buildings, but more general standards can be found in the previous section of this Pattern Book. Refer to the following pages for general architectural style standards:

Building Composition & Massing . . . . .	26
Building Configuration . . . . .	27
Building Materials & Details. . . . .	28
Window & Openings . . . . .	32
Doors . . . . .	39
Roofs. . . . .	40
Porches, Stoops, Decks, & Balconies. . . . .	46
Chimneys . . . . .	49
Fences, Walls & Hedges . . . . .	53



# Village Center Mixed-Use & Commercial Architectural Standards

## Lot Patterns

### Village Center - Attached

#### Lot Width

Minimum	18 ft.
Maximum	200 ft.

#### Principal Building

Front Setback	0 ft. min. 15 ft. max.*	<b>A</b>
Front Encroachment	If building has a Stoop, Dining Yard or Gallery, it may extend into the Front Setback*	
Side Setback	0 ft. min.	<b>B</b>
Rear Setback	3 ft. min. or 15 ft. min. from the centerline of the rear alley (if lot is alley loaded); whichever is larger	<b>C</b>
Building Height	3 stories max.	

#### Outbuilding (allowed in the "Outbuilding Zone" as shown)

Front Setback	20 ft. min. behind Facade of house, in Backyard
Side Setback	0 ft. min.
Rear Setback	5 ft. min.
Building Height	2 stories max.

\* 15 ft. max setback is not shown in diagram. If Principal Building is placed at a setback greater than 0 ft., there will be a Front Encroachment allowed in the Front Setback for Stoops, Dining Yards or Galleries; as shown in the Village Center: Detached diagram on the following page.

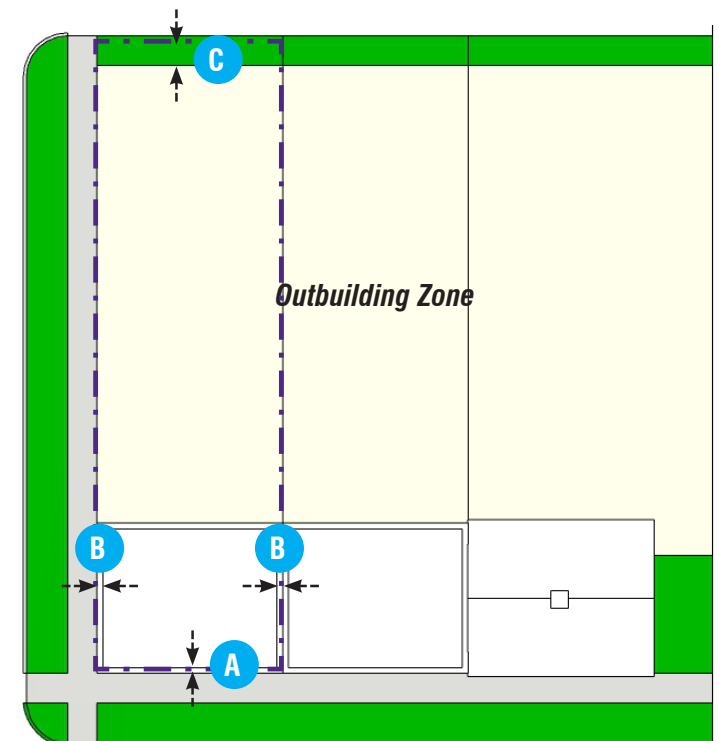
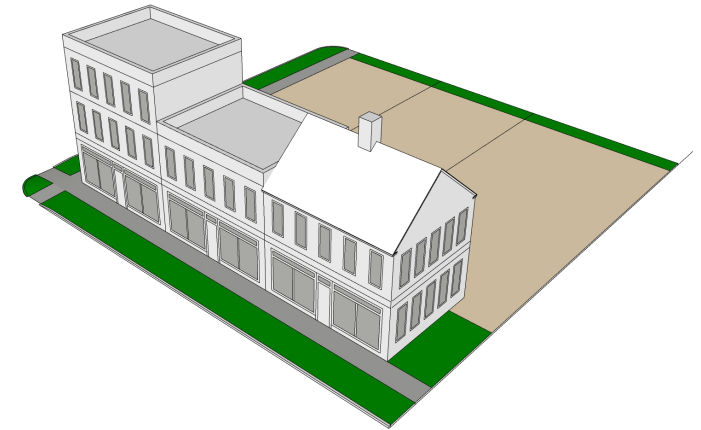



# Village Center Mixed-Use & Commercial Architectural Standards

## Lot Patterns

### Village Center - Detached

#### Lot Width

Minimum	25 ft.
Maximum	200 ft.

#### Principal Building

Front Setback	0 ft. min.* 15 ft. max.	<b>A</b>
Front Encroachment	If building has a Stoop, Dining Yard or Gallery, it may extend into the Front Setback*	
Side Setback	5 ft. min.	<b>B</b>
Rear Setback	3 ft. min. or 15 ft. min. from the centerline of the rear alley (if lot is alley loaded); whichever is larger	<b>C</b>
Building Height	3 stories max.	

#### Outbuilding (allowed in the "Outbuilding Zone" as shown)

Front Setback	20 ft. min. behind Facade of house, in Backyard
Side Setback	5 ft. min.
Rear Setback	5 ft. min.
Building Height	2 stories max.

\* 0 ft. min. setback is not shown in diagram. If Principal Building is placed at 0 ft. setback, there will be no Front Encroachment allowed for Stoops, Dining Yards or Galleries; as shown in the Village Center: Attached diagram on the previous page.

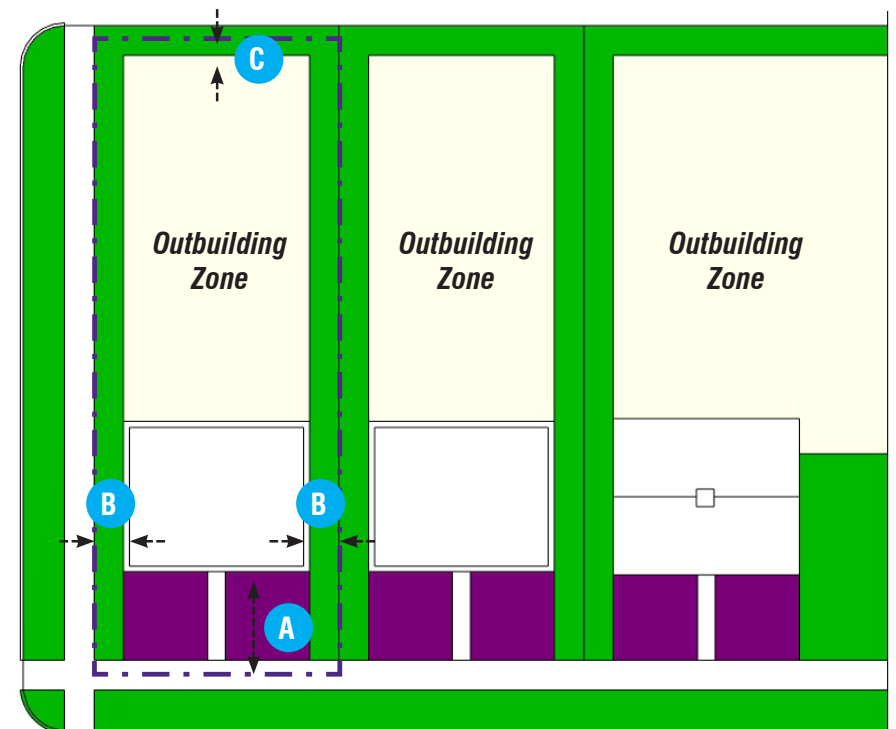
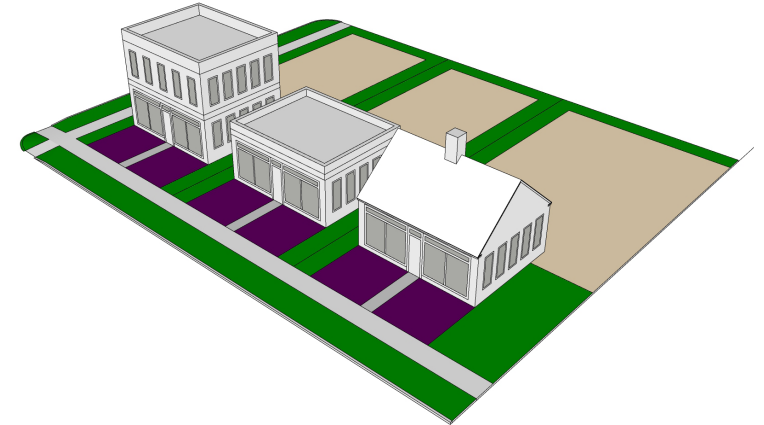

# Village Edge Mixed-Use & Commercial Architectural Standards

## Lot Patterns

### Village Edge - Attached

#### Lot Width

Minimum	18 ft.
Maximum	100 ft.

#### Principal Building

Front Setback	10 ft. min. 30 ft. max.*	<b>A</b>
Front Encroachment	If building has a Porch, Stoop, Dining Yard, Commercial Porch or Gallery, it may extend into the Front Setback*	
Side Setback	0 ft. min.	<b>B</b>
Rear Setback	3 ft. min. or 15 ft. min. from the centerline of the rear alley (if lot is alley loaded); whichever is larger	<b>C</b>
Building Height	3 stories max. for Multifamily or Mixed Use Buildings; otherwise 2 stories max.	

#### Outbuilding (allowed in the "Outbuilding Zone" as shown)

Front Setback	20 ft. min. behind Facade of house, in Backyard
Side Setback	0 ft. min.
Rear Setback	5 ft. min.
Building Height	2 stories max.

\* 30 ft. max. setback is not shown in diagram.

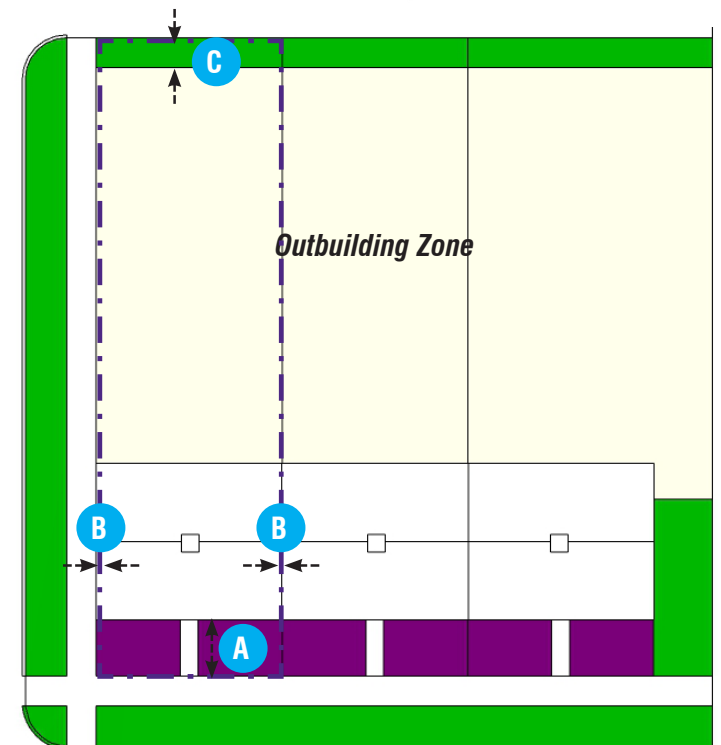
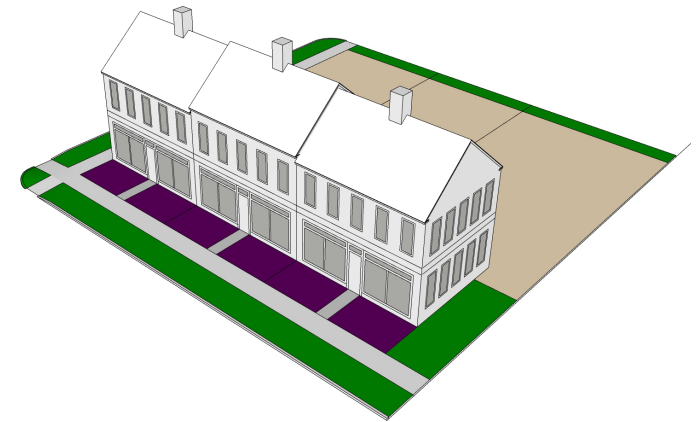



# Village Edge Mixed-Use & Commercial Architectural Standards

## Lot Patterns

### Village Edge - Detached

#### Lot Width

Minimum	25 ft.
Maximum	100 ft.

#### Principal Building

Front Setback	10 ft. min.* 30 ft. max.	<b>A</b>
Front Encroachment	If building has a Porch, Stoop, Dining Yard, Commercial Porch or Gallery, it may extend into the Front Setback*	
Side Setback	5 ft. min.	<b>B</b>
Rear Setback	3 ft. min. or 15 ft. min. from the centerline of the rear alley (if lot is alley loaded); whichever is larger	<b>C</b>
Building Height	3 stories max. for Multifamily or Mixed Use Buildings; otherwise 2 stories max.	

#### Outbuilding (allowed in the "Outbuilding Zone" as shown)

Front Setback	20 ft. min. behind Facade of house, in Backyard
Side Setback	5 ft. min.
Rear Setback	5 ft. min.
Building Height	2 stories max.

\* 10 ft. min. setback is not shown in diagram.

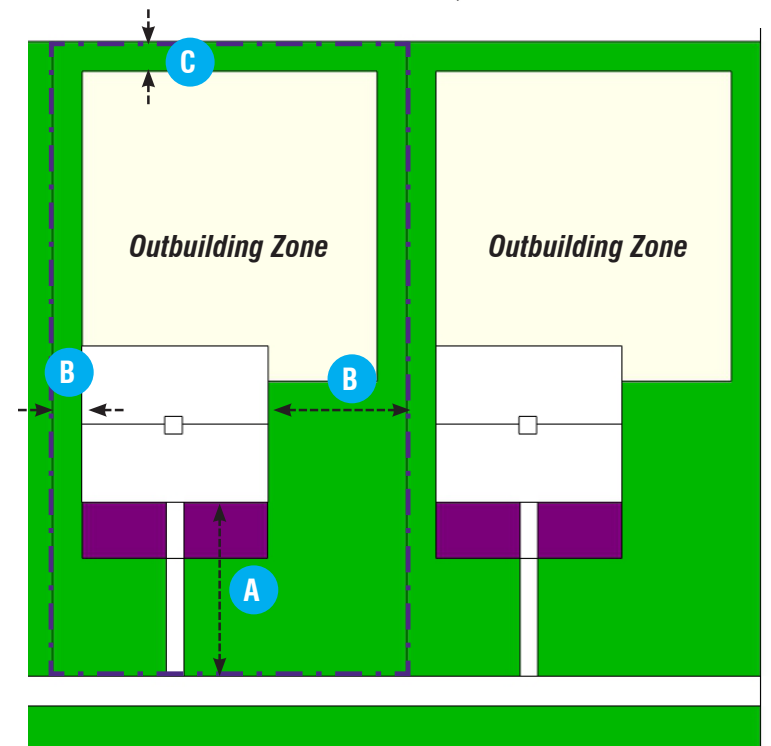
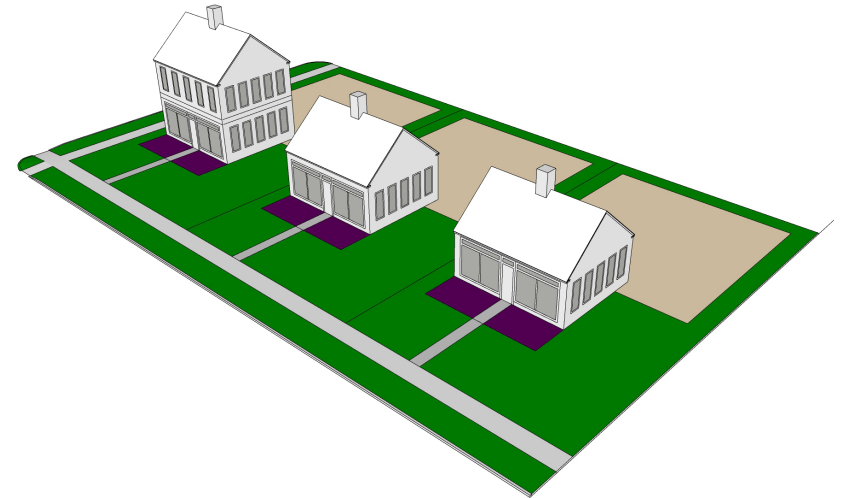



# Mixed-Use & Commercial Architectural Standards

## Private Frontage Types

The Private Frontage is the area between the building Facade and the public right-of-way, and can take on a number of configurations, depending on the type of building and primary use of the building. The following table illustrates four different types of Private Frontage types that are appropriate to Sewanee Commercial Buildings, along with the Character Districts each are permitted in.

Frontage Type	Permitted Districts
 	<p><b>Dining Yard:</b> A Frontage type relatively unique to Sewanee wherein the Facade is set back from the Frontage Line with a paved area between the building and the sidewalk that accommodates outdoor dining or seating. This may be used with or without a fence to maintain thoroughfare spatial definition. The Dining Yard Frontage Type may be combined with a Shopfront Frontage, and is for ground floor dining or entertainment use.</p> <p><b>Permitted Districts</b> Village Center Village Edge</p>
 	<p><b>Commercial Porch:</b> A Frontage type found in many rural downtowns wherein the Facade is set back from the Frontage Line with an attached porch permitted to encroach into the Front Setback. The porch is typically raised no more than six inches higher than the sidewalk, or may be level with the sidewalk to avoid the need for a ramp. A Commercial Porch may be combined with a Shopfront Frontage, or may have windows and doors more typical of a residential use. This type is for ground floor commercial use only.</p> <p><b>Permitted Districts</b> Village Edge</p>

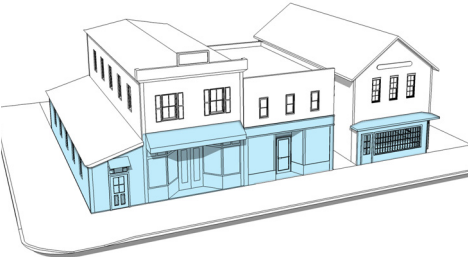

Frontage Type			Permitted Districts
		<p><b>Shopfront:</b>                      A Frontage wherein the Facade is aligned close to or at the Frontage Line with the building entrance at sidewalk grade. This type is conventional for retail use. It has a substantial glazing on the sidewalk level and may include an awning that may overlap the sidewalk. This type is for ground floor commercial use only.</p>	<p><b>Village Center</b>  <b>Village Edge</b></p>
		<p><b>Gallery:</b>                      A Frontage wherein the Facade is aligned close to the Frontage line with an attached cantilevered shed or a lightweight colonnade. This type is intended for buildings with ground floor commercial or retail uses and the Gallery may not encroach into the right-of-way.</p>	<p><b>Village Center</b></p>

# Mixed-Use & Commercial Architectural Standards

## Building Types

The following table illustrates the two different classifications of Commercial Building Types considered appropriate for construction in Sewanee. Within each Building Type category, buildings may vary widely in character, style, massing and configuration. The table provides a list of permitted Character Districts for each Building Type, as well as the permitted Frontage Types for that building.

Building Type		Permitted Districts	Permitted Frontage Types	Additional Information
	 <p><b>Live/Work:</b> A small to medium-sized attached or detached structure that consists of a flexible space used for artisan, studio, service, or retail uses, and a residential unit above and/or behind. Both the flex space and the residential unit are internally connected.</p>	<p>Village Center Village Edge</p>	<p>Porch Stoop Dining Yard Commercial Porch Shopfront Gallery</p>	<p>Ground floor use shall be accessed from the Primary Frontage. Residential use may share an entry or have a separate entry.</p>
	 <p><b>Mixed Use:</b> A typically attached building that provides a vertical and/or horizontal mix of uses typically designed to facilitate pedestrian-oriented retail, hospitality, service or office uses on the ground floor, with upper floors typically designed for residential or office uses.</p>	<p>Village Center Village Edge</p>	<p>Dining Yard Commercial Porch Shopfront Gallery</p>	<p>Upper floors shall be accessed by a common entry</p>



# Mixed-Use & Commercial Architectural Standards

## Shopfront Frontage

The following shall be applicable to Shopfront Frontages of buildings in the Sewanee Village:

As used herein, “shopfront” includes the exterior of the ground-floor of each Facade, the porches and areas leading to the entry, the doors, sidelights and transoms, the show windows, and display platforms and devices, including lighting and signs visible from a Public Frontage or any parking lot. The entire Shopfront should be designed as a unified whole.

### Construction

One continuous load-bearing steel beam shall carry the entire load of the Facade to the partition walls so that changing the Shopfront is facilitated with no structural impediment.

Shopfronts shall have internal structural support to allow back-bolted installation of signs and awnings, whether or not signs or awnings are installed at the time of initial construction.

A minimum clearance of eight feet shall be maintained between the pavement and any awning, light or sign.

### Materials

Except for the window glazing, Shopfront Frontages shall be made of wood, natural stone, metal, or unpainted or painted brick or terracotta.

Wood components shall be painted, or transparent- or opaque-stained.

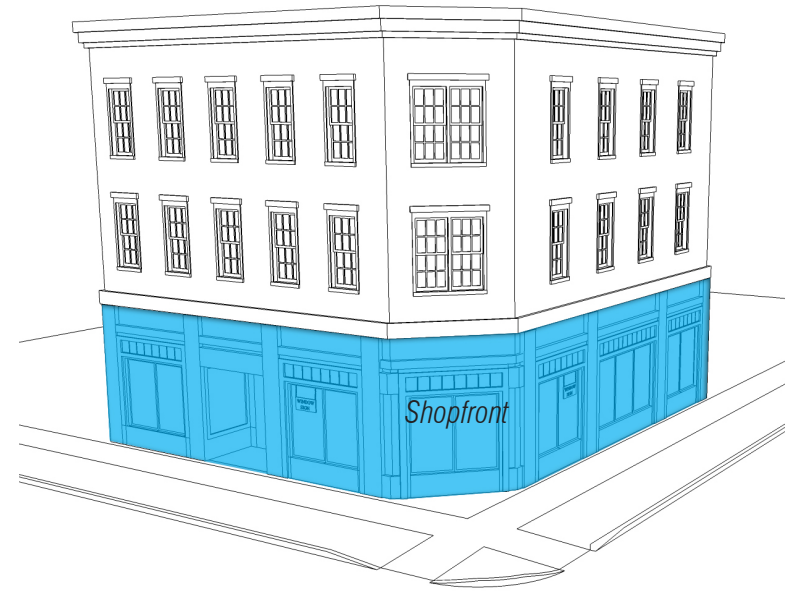

# Mixed-Use & Commercial Architectural Standards

## Shopfront Frontage

### Shopfront vs. Commercial Porch

Traditionally, a Shopfront Frontage (refer to the “Public Frontages” section of this Pattern Book) consists of storefront windows that are single, large panes of glass set on a kneewall and incorporating awnings, transoms and other features to allow display of goods and services. Sewanee has several such Shopfront frontages pictured at top right. This type of Shopfront shall be required for the majority of commercial and mixed use buildings in the Village Center.

However, downtown Sewanee also has a number of existing commercial buildings that have a more residential character (pictured at bottom right) with single or grouped windows, partial or full glass doors, and porches or awnings. This type of commercial frontage emphasizes the unique character of Sewanee, and will continue to be allowed in the Village Edge Character Area, and on any existing commercial buildings with such Frontage.





# Mixed-Use & Commercial Architectural Standards

## Shopfront Frontage

### Shopfront Windows

Windows shall sit on a 12" to 24" high kneewall at the frontage. Windowsills shall be at the kneewall (see illustration at right).

### Shopfront Awnings

All awnings on a single business shall be identical in color and form; all awnings on a single building with multiple businesses shall be identical in form, but are allowed to vary in color.

One awning per window is permitted provided it does not conceal architectural features (such as cornices, columns, pilasters, or decorative details).

Awnings shall be a minimum depth of 8' and shall have a clearance of 8' minimum at its lowest point.

Awnings shall be rectangular in elevation and triangular in cross-section with straight edges and no side panels or soffit (illustrations at right). Awnings of the quarter-round or domed variety are not allowed.

Awnings shall have a metal structure covered with non-translucent canvas, synthetic canvas or painted metal.

Rigid or fixed awnings or canopies shall be designed to be an integral part of the structure. Rigid or fixed awnings or canopies shall not be added to existing structures.

Awnings shall not be backlit.

Awnings are allowed to be retractable.



12" - 42" kneewall below glass windows.

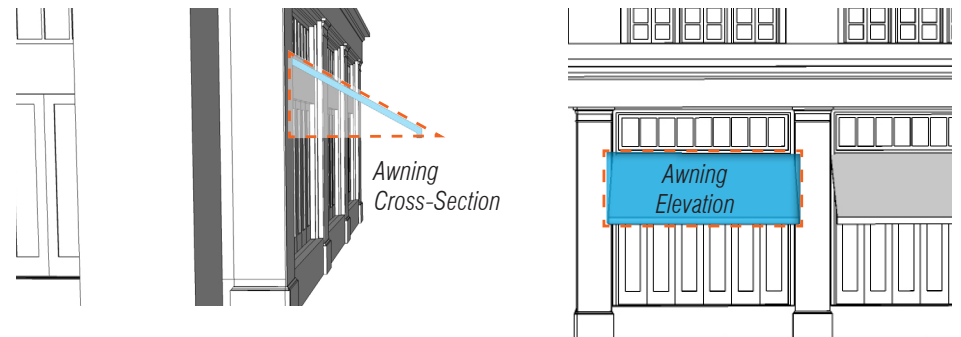



# Appropriate Mixed-Use & Commercial Architecture

## Local Precedent - Mixed Use & Commercial





# Appropriate Mixed-Use & Commercial Architecture

## Regional Precedent - Mixed Use & Commercial





# Appropriate Mixed-Use & Commercial Architecture

## National Precedent - Mixed Use & Commercial





This page is Intentionally blank



# Sewanee Village + Signage Standards





# Signage Standards

## Introduction

### How to Use The Signage Standards

It is important to note that the goal of these Signage Standards is not to stifle the creativity of leaseholders, business owners and developers. Rather it is intended to provide a clear framework for appropriate downtown signage into which individuals can incorporate customized forms and details.

#### Step 1: Character Districts

The first step is to identify the Character District that the leasehold is located in. There are four different Character Districts. For an up-to-date map showing the boundaries of each District, contact the Lease Office.

Generally:

- The Village Center includes the blocks of downtown that directly surround the intersection between Highway 41A and University Avenue. All of the sign types described here are appropriate in this District.
- The Village Edge includes the blocks surrounding the Village Center, extending up University Avenue, down Highway 41A, and south of the planned civic spaces at the main intersection. All of the sign types described here are appropriate in this District.
- The Village Neighborhoods are the primarily residential areas within a five- to fifteen-minute walk of the intersection of University Avenue and Highway 41A. Only a few residential sign types are allowed in this District.
- The Cottage Courts will be small areas of new construction, intended to provide additional housing options in Sewanee. Only a few residential sign types are allowed in this District.

#### Step 2: Sign Type

The second step is to determine the type of sign desired for the building/leasehold and use the Signage Standards Summary to determine whether that type is permitted in the Character District in which the building/leasehold is located. If so, move on to Step 3. If not, check the Sign Standards Summary for other sign types that may be more appropriate for the District.

#### Step 3: Sign Standards

Once the leaseholder/business owner has determined which of the Sign Types are appropriate, the final step is to review the specific standards for placement, dimensions, and design and to submit an application to the Lease Committee for Design Review. Please contact the Lease Office for the most current Design Review submittal requirements.

### Illustrated Concepts & Terms: Frontage, Facades & Elevations



The Principal Frontage is the “front” of the lot, or the side that enfronts the public right-of-way from which the building is addressed, and that which the adjacent building(s) face. Main entrances to all buildings shall be from the Principal Frontage, and the Facade must be parallel to the Principal Frontage.

The Secondary Frontage applies to corner lots only, and describes the “side street” from which the building may have a secondary entrance.

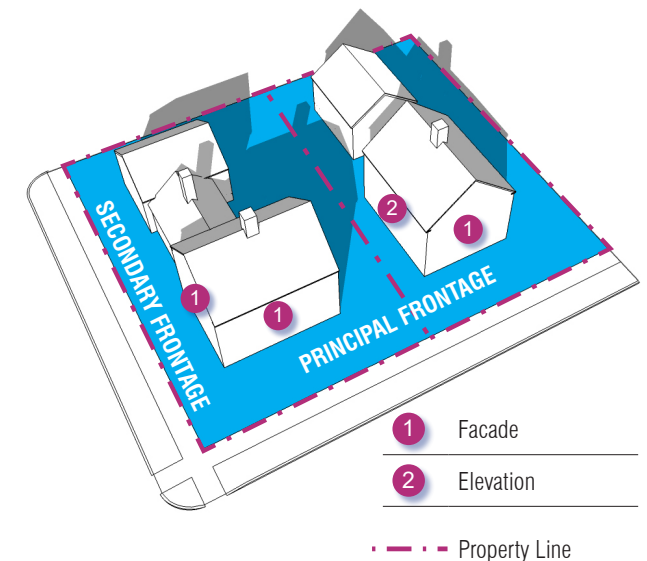
The term “Facade” is used to describe any Elevation of the building that is oriented toward the Principal or Secondary Frontage. Elevations are all other sides of the building. To summarize, all Facades are Elevations but not all Elevations are Facades.



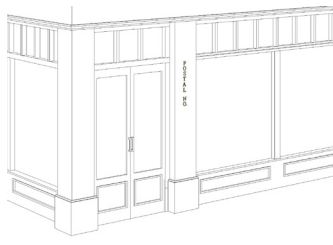

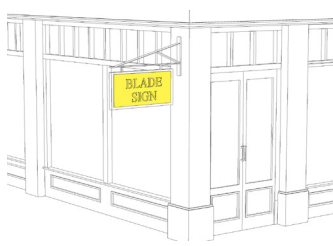
# Signage Standards Summary



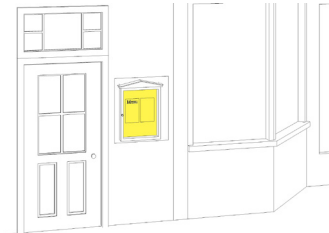

Sewanee Village Sign Type	Illustration	Allowed Districts	Specific Standards
<p><b>Address Sign:</b></p> <p>A sign that consists of a numeric reference to a building or street, mounted on the building.</p>		<p><b>Village Center</b></p> <p><b>Village Edge</b></p> <p><b>Village Neighborhood</b></p> <p><b>Cottage Court</b></p>	<p><a href="#">Page 5</a></p>
<p><b>Awning Sign:</b></p> <p>An awning that contains a retail tenant sign which may be painted, screen printed, or appliquéd on the valance of the awning.</p>		<p><b>Village Center</b></p> <p><b>Village Edge</b></p>	<p><a href="#">Page 6</a></p>
<p><b>Band Sign:</b></p> <p>A sign that is flat against the Facade consisting of individual cut letters applied directly to the building, or painted directly on the surface of the building. Band signs are placed directly above the main entrance and often run horizontally along the entablature of traditional buildings. Band Signs are typically intended to be seen from a distance and are often accompanied by additional pedestrian-scaled signage. May also be referred to as a Facade Sign.</p>		<p><b>Village Center</b></p> <p><b>Village Edge</b></p>	<p><a href="#">Page 7</a></p>
<p><b>Blade Sign:</b></p> <p>A sign mounted perpendicular to a building Facade Wall, typically hung from decorative cast or wrought iron brackets in a manner that permits them to swing slightly. These signs are small, pedestrian-scaled, and easily read from both sides. Blade signs should be hung well out of reach of pedestrians and all exposed edges of the sign should be finished. May also be referred to as a Projecting Sign.</p>		<p><b>Village Center</b></p> <p><b>Village Edge</b></p>	<p><a href="#">Page 8</a></p>



# Signage Standards Summary

Sewanee Village Sign Type	Illustration	Allowed Districts	Specific Standards
<p><b>Marquee Sign:</b></p> <p>A vertical sign that is located either along the face where it projects perpendicular to the Facade. These signs often extend beyond the parapet of the building, but may also terminate below the cornice or eave. Marquee Signs often have neon lettering used in conjunction with painted lettering.</p>		<p><b>Village Center</b></p> <p><b>Village Edge</b></p>	<p><a href="#">Page 9</a></p>
<p><b>Outdoor Display Case:</b></p> <p>Outdoor Display Case signs are typically found on institutional or commercial buildings, such as churches, restaurants, museums, schools, performing arts and community centers. They may contain information about current events or offerings. May also be referred to and used as Menu Signs.</p>		<p><b>Village Center</b></p> <p><b>Village Edge</b></p>	<p><a href="#">Page 10</a></p>
<p><b>Plaque Sign:</b></p> <p>This sign type consists of either a panel or individual letters applied to a building, listing the names of businesses or building tenants. May also be referred to as Nameplate Sign.</p>		<p><b>Village Center</b></p> <p><b>Village Edge</b></p> <p><b>Village Neighborhood</b></p> <p><b>Cottage Court</b></p>	<p><a href="#">Page 11</a></p>
<p><b>Porch Sign:</b></p> <p>Signs that are mounted on a porch, typically hung over the entrance.</p>		<p><b>Village Center</b></p> <p><b>Village Edge</b></p> <p><b>Village Neighborhood</b></p> <p><b>Cottage Court</b></p>	<p><a href="#">Page 12</a></p>

# Signage Standards Summary

Sewanee Village Sign Type	Illustration	Allowed Districts	Specific Standards
<p><b>Sidewalk Sign:</b></p> <p>A sign that provides secondary signage and may be used to announce daily specials, sales, or point to shops located off the sidewalk. They may be painted wood panels or cut wood shapes. Traditional slate boards are highly recommended. Chaser lights or aluminum signs may not be used. May also be referred to as a Sandwich Board or Sandwich Sign.</p>		<p><b>Village Center</b> <b>Village Edge</b></p>	<p><a href="#">Page 13</a></p>
<p><b>Wall and Building Sign:</b></p> <p>Signs that are flat against the Facade. They are intended to be visible from a greater distance. Wall and Building signs that do not provide signage for a specific business (e.g. artistic Wall Mural) are subject to approval by the Village Planner.</p>		<p><b>Village Center</b> <b>Village Edge</b></p>	<p><a href="#">Page 14</a></p>
<p><b>Window Sign:</b></p> <p>Signs that are professionally painted consisting of individual letters and designs, applied directly on the inside of a window or hanging adjacent to the inside face of glass.</p>		<p><b>Village Center</b> <b>Village Edge</b></p>	<p><a href="#">Page 15</a></p>
<p><b>Yard Sign:</b></p> <p>Signs that are mounted in a yard between the public Right-of-Way (ROW) and the building Facade. Signs mounted in a yard may be placed parallel or perpendicular to the ROW.</p>		<p><b>Village Center</b> <b>Village Neighborhood</b></p>	<p><a href="#">Page 16</a></p>



# Signage Standards

## Address Sign

### Allowed Districts:

Village Center

Village Edge

Village Neighborhood

Cottage Court



### DESCRIPTION

A sign that consists of a numeric reference to a building or street, mounted on the building.

### DIMENSIONS

Quantity (max)	1 per address
Area	72 sq. in
Width / Height	max 18 in / max 24 in
Depth / Projection	max 3 in
Clearance	min 4.5 ft
Letter Height	min 4 in, max 6 in, measured vertically

### STANDARDS

In addition to all other applicable standards, each Band Sign:

- shall have the address number attached to the building in proximity to the main building entrance or at a mailbox.
- shall be easily visible; and
- shall be constructed of durable, weatherproof materials.

# Signage Standards

## Awning Sign



### DESCRIPTION

An awning that contains a retail tenant sign which may be painted, screen printed, or appliquéd on the valance of the awning.

### DIMENSIONS

Quantity (max)	1 per window
Width / Height	max width = width of facade max height = n/a letters, numbers, and graphics covering no more than 70% of the valance area
Depth / Projection	min 8 ft fully extended, edge of sidewalk, whichever is less
Clearance	min 8 ft
Letter Height	min 5 in, max 10 in
Valance Height	max 12 in

### STANDARDS

In addition to all other applicable standards, each Awning Sign:

- shall only be applied to an awning that complies with the Sewanee Village Pattern Book standards;
- if located over the public right of way shall require the approval of Franklin County;
- shall be limited to the valance of the awning;
- shall contain only the business name, logo, and/or street address;
- shall not be internally illuminated or backlit.
- shall be made of opaque material.



# Signage Standards

## Band Sign

### Allowed Districts:

Village Center

Village Edge



### DESCRIPTION

A sign that is flat against the Facade consisting of individual cut letters applied directly to the building, or painted directly on the surface of the building. Band signs are placed directly above the main entrance and often run horizontally along the entablature of traditional buildings. Band Signs are typically intended to be seen from a distance and are often accompanied by additional pedestrian-scaled signage. May also be referred to as a Facade Sign.

### DIMENSIONS

Quantity (max)	1 per Facade, per business
Area	1.5 sf per linear ft Facade
Width / Height	max 90% width of Facade / max 3 ft
Depth / Projection	max 7 in
Clearance	min 7 ft
Letter Height	max 18 in

### STANDARDS

In addition to all other applicable standards, each Band Sign:

- shall be applied to the first story Facade and not project vertically above the roof line;
- shall include only letters, background, lighting, and an optional logo, with such information shall consist only of the name and/or logo of the businesses located in such building;
- shall not list products, sales, or other promotional messages, or contact information;
- shall have letters individually attached to the wall, on a separate background panel affixed to the wall, or printed or etched on the same surface as the background;
- shall be externally illuminated by lights shielded from direct view to reduce glare;
- shall not have exposed electrical raceways, conduits or wiring;
- should be placed in consideration of the building architecture and in vertical alignment with the center of an architectural element such as a storefront window or entrance, or centered over the bay or overall space occupied by the business, all without interruption or obscuring an architectural element or causing visual disharmony; and
- shall be constructed of durable, weatherproof materials.

# Signage Standards

## Blade Sign

### Allowed Districts:

Village Center

Village Edge

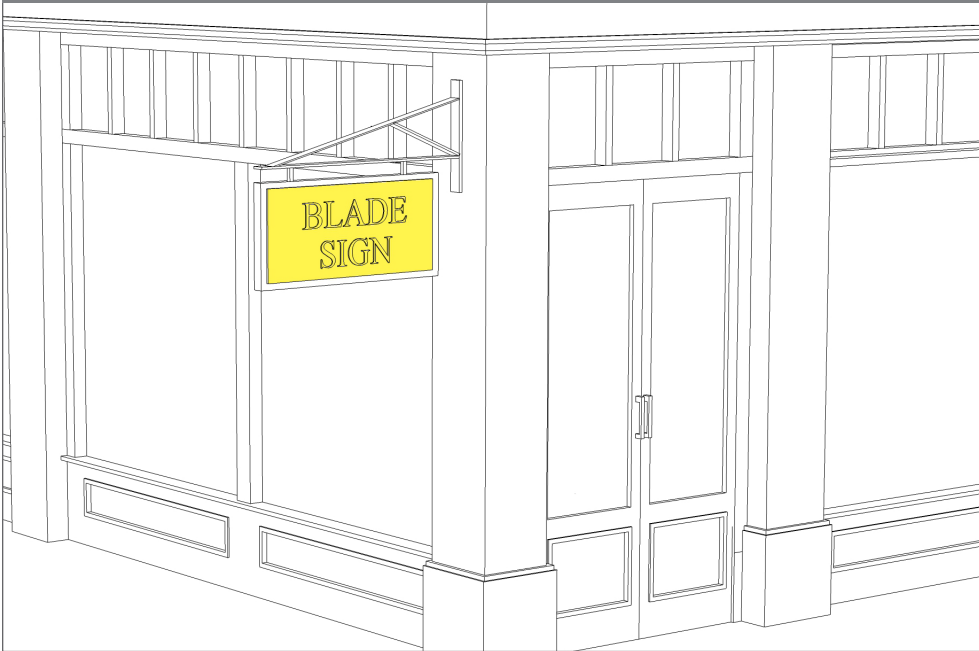

### DIMENSIONS

Quantity (max)	1 per business, no closer than 18 ft from another Blade Sign
Area	6 sf
Width / Height	max 2 ft / max 4 ft
Depth / Projection	max 4 ft
Clearance	min 8 ft clear above the sidewalk
Letter Height	max 8 in

### DESCRIPTION

A sign mounted perpendicular to a building Facade Wall, typically hung from decorative cast or wrought iron brackets in a manner that permits them to swing slightly. These signs are small, pedestrian-scaled, and easily read from both sides. Blade signs should be hung well out of reach of pedestrians and all exposed edges of the sign should be finished. May also be referred to as a Projecting Sign.

### STANDARDS

In addition to all other applicable standards, each Blade Sign:

- if located over the public right of way shall require the approval of Franklin County;
- shall be permanently installed perpendicular to the Façade;
- shall be constructed of durable, weatherproof materials.



# Signage Standards

## Marquee Sign

### Allowed Districts:

Village Center

Village Edge



### DESCRIPTION

A vertical sign that is located either along the face where it projects perpendicular to the Facade. These signs often extend beyond the parapet of the building, but may also terminate below the cornice or eave. Marquee Signs often have neon lettering used in conjunction with painted lettering.

### DIMENSIONS

Quantity (max)	1 per Principal Frontage
Width / Height	centered on and no more than 4 ft wider than Principal Entrance Bay
Depth / Projection	min 4 ft, max 10 ft
Clearance	min 10 ft from sidewalk
Letter Height	removable letter height max 6 in, business name and logo height max 36 in
Distance from Curb	per Franklin County standards and approval

### STANDARDS

In addition to all other applicable standards, each Marquee Sign:

- shall not be internally lighted or backlit except behind the panels from which removable letters are hung and shall be lighted with neon tubing or other external means;
- shall be located only above the Principal Entrance of a building and attached parallel to the Facade;
- shall not have any supports more than eight (8) feet deep and all anchors, bolts, and supporting rods must be concealed within its interior;
- if located over the public right of way shall require the approval of Franklin County;
- shall together with all anchors, bolts, supporting rods and braces, be constructed of high quality non-combustible or non-corrodable components and materials and shall be designed by a structural engineer; and
- shall be constructed of durable, weatherproof materials.

# Outdoor Display Case

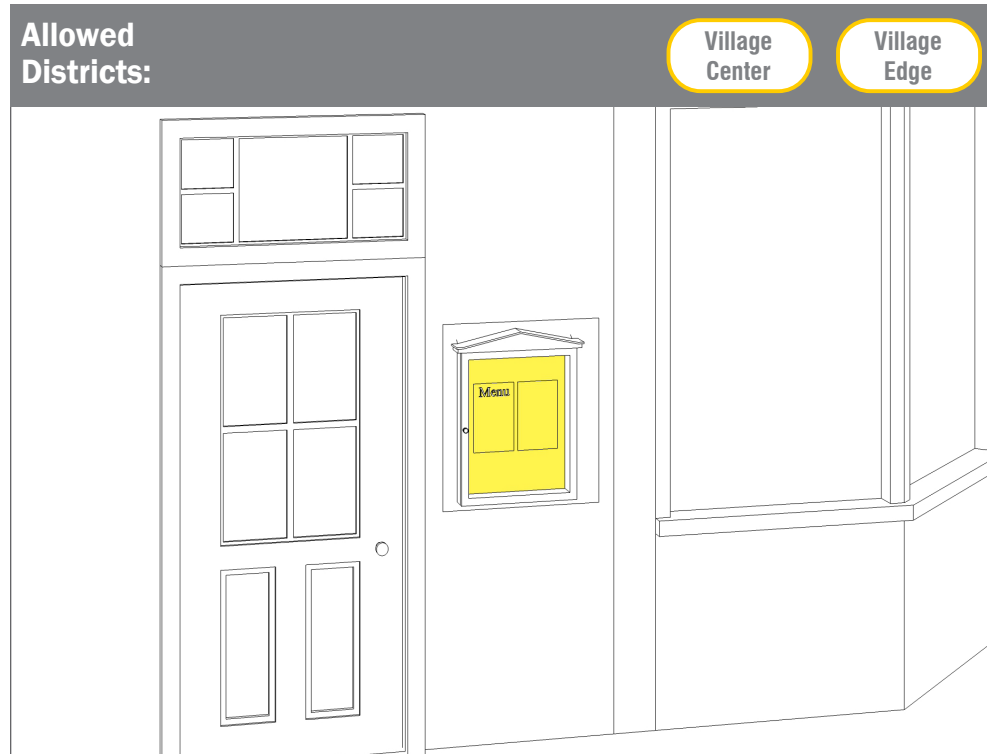

## DESCRIPTION

Outdoor Display Case signs are typically found on institutional or commercial buildings, such as churches, restaurants, museums, schools, performing arts and community centers. They may contain information about current events or offerings. May also be referred to and used as Menu Signs.

## DIMENSIONS

Quantity (max)	1 per Principal
Area	max 6 sf
Width / Height	max 3.5 ft square
Depth / Projection	max 5 in
Clearance	min 4 ft
Letter Height	n/a

## STANDARDS

- In addition to all other applicable standards, each Outdoor Display Case:
- shall be attached to and parallel with the first floor Façade;
  - shall not exceed six (6) square feet, except in the case of Theaters, in which case they shall not exceed 20 square feet;
  - may be externally illuminated or by a recessed light source within the cabinet;
  - shall not be attached to or be placed within shopfront windows; and
  - shall be constructed of durable, weatherproof materials.



# Signage Standards

## Plaque Sign

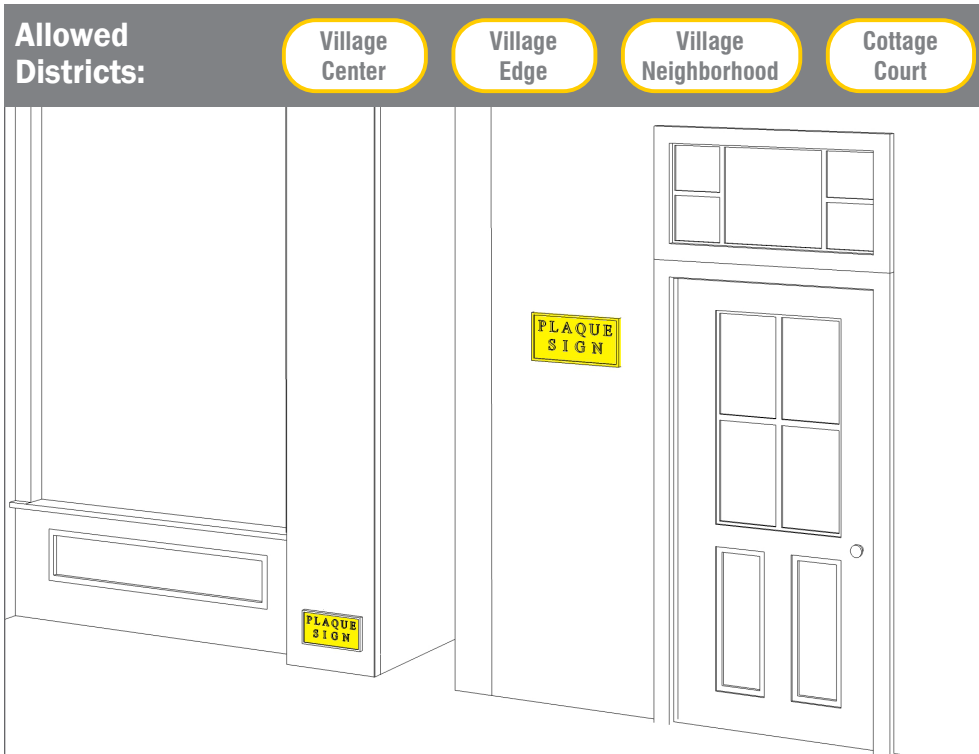

### DESCRIPTION

This sign type consists of either a panel or individual letters applied to a building, listing the names of businesses or building tenants. May also be referred to as Nameplate Sign.

### DIMENSIONS

Quantity (max)	1 per Address
Area	max 3 sf
Width / Height	max 18 in / max 2 ft
Depth / Projection	max 3 in

### STANDARDS

In addition to all other applicable standards, each Plaque Sign:

- shall only provide the name, address or logo of an owner, tenant, and/or the building to which it is affixed;
- shall consist of either a panel or individual characters applied to a building wall within four(4) feet of an entrance to the building;
- may not be backlit; and
- shall be constructed of durable, weatherproof materials.

# Signage Standards

## Porch Sign

### Allowed Districts:

Village Center

Village Edge

Village Neighborhood

Cottage Court



### DESCRIPTION

Signs that are mounted on a porch, typically hung over the entrance.

### DIMENSIONS

Quantity (max) 1 per address ( 2 / corner bldgs)

Area max 6 sq ft

Width / Height max 90% width of Entrance / max 2 ft

Depth / Projection n/a

Clearance min 7 ft

Letter Height max 8 in

### STANDARDS

In addition to all other applicable standards, each Porch Sign:

- shall be hung above the entrance to the porch or elsewhere on the architrave (beam at top of columns); and
- shall be permanently installed parallel to the facade of the building;
- may be externally lit by lights shielded from direct view to reduce glare; and
- shall be constructed of durable, weatherproof materials.



# Signage Standards

## Sidewalk Sign

### Allowed Districts:

Village Center

Village Edge



### DIMENSIONS

Quantity (max)	1 per business
Area	max 8 sf
Width / Height	max 26 in / max 42 in
Depth / Projection	n/a
Clearance	n/a
Letter Height	n/a

### DESCRIPTION

A sign that provides secondary signage and may be used to announce daily specials, sales, or point to shops located off the sidewalk. They may be painted wood panels or cut wood shapes. Traditional slate boards are highly recommended. Chaser lights or aluminum signs may not be used. May also be referred to as a Sandwich Board or Sandwich Sign.

### STANDARDS

In addition to all other applicable standards, each Sidewalk Sign:

- shall consist of freestanding, double-sided signs placed at the entrance to a business in a primarily pedestrian environment;
- shall be permitted for each business;
- shall be moved inside during high winds or other weather conditions that might pose a hazard to public safety;
- shall maintain a minimum 5' clear pedestrian travel way on the sidewalk; and
- shall be constructed of durable, weatherproof materials.

# Wall and Building Sign



## DESCRIPTION

Signs that are flat against the Facade. They are intended to be visible from a greater distance. Wall and Building signs that do not provide signage for a specific business (e.g. artistic Wall Mural) are subject to approval by the Village Planner.

## DIMENSIONS

Quantity (max)	1 per business
Area	max 16 sf
Width / Height	max 26 in / max 96 in
Depth / Projection	3 inches
Clearance	4 feet
Letter Height	n/a

## STANDARDS

In addition to all other applicable standards, each Wall Sign:

- shall not project vertically above the roof line;
- shall include only letters, background, lighting, and an optional logo, with such information shall consist only of the name and/or logo of the businesses located in such building;
- shall not list products, sales, or other promotional messages, or contact information;
- shall have letters individually attached to the wall, on a separate background panel affixed to the wall, or printed or etched on the same surface as the background;
- shall be externally illuminated by lights shielded from direct view to reduce glare or halo lighting behind opaque lettering;
- shall not have exposed electrical raceways, conduits or wiring;
- should be placed in consideration of the building architecture and in vertical alignment with the center of an architectural element such as a storefront window or entrance, or centered over the bay or overall space occupied by the businesses, all without interruption or obscuring an architectural element or causing visual disharmony; and
- shall be coordinated in terms of scale, placement, colors and materials with any other such sign on the Facade of the building; and
- shall be constructed of durable, weatherproof materials.



# Signage Standards

## Window Sign

### Allowed Districts:

Village Center

Village Edge



### DESCRIPTION

Signs that are professionally painted consisting of individual letters and designs, applied directly on the inside of a window or hanging adjacent to the inside face of glass.

### DIMENSIONS

Quantity (max)	1 per window
Area	max 25% of glass onto which it is applied or behind which it is hanging
Width / Height	varies
Depth / Projection	n/a
Clearance	4 ft
Letter Height	8 in

### STANDARDS

In addition to all other applicable standards, each Window Sign:

- shall be of one of the following types:
  - letters painted or applied directly on the window
  - hanging signs that hang from the ceiling behind the window
  - neon signs - non flashing or moving
  - door signs applied to or hanging inside the glass portion of an entrance doorway
- shall not interfere with the primary function of windows, which is to enable passersby and public safety personnel to see through windows into premises and view product displays; and
- may list services and/or products sold on the premises, or provide phone numbers, operating hours or other messages, provided that the total aggregate area of these messages shall not exceed the limit provided above.

# Signage Standards

## Yard Sign

### Allowed Districts:

Village Edge

Village Neighborhood



### DESCRIPTION

Signs that are mounted in a yard between the public Right-of-Way (ROW) and the building Facade. Signs mounted in a yard may be placed parallel or perpendicular to the ROW.

### DIMENSIONS

Quantity (max)	1 per building
Area	12 sf
Width / Height of Sign panel	max 48 in / max 40 in
Clearance	n/a
Apex	6 ft
Letter Height	max 10 in
Distance from frontage line	min 2 ft

### STANDARDS

In addition to all other applicable standards, each Yard Sign:

- shall be externally illuminated by lights shielded from direct view to reduce glare;
- can be single- or double- post;
- shall be set perpendicular to the building; and
- shall be made of durable, weatherproof materials.



# Resources

---

Cusato, Marianne, Ben Pentreath, Richard Franklin. Sammons, and Leon Krier. *Get Your House Right: Architectural Elements to Use & Avoid*. New York: Sterling, 2007.

Foster, Gerald L. *American Houses: A Field Guide to the Architecture of the Home*. Boston: Houghton Mifflin, 2004.

McAlester, Virginia, and A. Lee McAlister. *A Field Guide to American Houses*. New York: Knopf, 1984.

Mouzon, Stephen A., and Susan M. Henderson. *Traditional Construction Patterns*. New York: McGraw-Hill, 2004.

Schweitzer, Robert. *Bungalow Colors: Exteriors*. Salt Lake City: Gibbs Smith, 2002.

Historic Preservation in Knoxville and Knox County; [www.knoxmpc.org/historic/edu/styles.htm](http://www.knoxmpc.org/historic/edu/styles.htm).

Vernacular Domestic Architecture; *The Tennessee Encyclopedia of History and Culture* Version 2.0; [tennesseeencyclopedia.net](http://tennesseeencyclopedia.net)